

# 60JB50K / 60105 直流齿轮减速电机 60JB50K/60105 PM DC GEAR MOTOR

**60mm 50K 齿轮减速**  
60mm 50K PLANETARY GEAR

**新产品! 大扭矩、低噪音产品!**

Nao Product! String torque and low noise product!

## ● 外形和安装尺寸 Dimensions

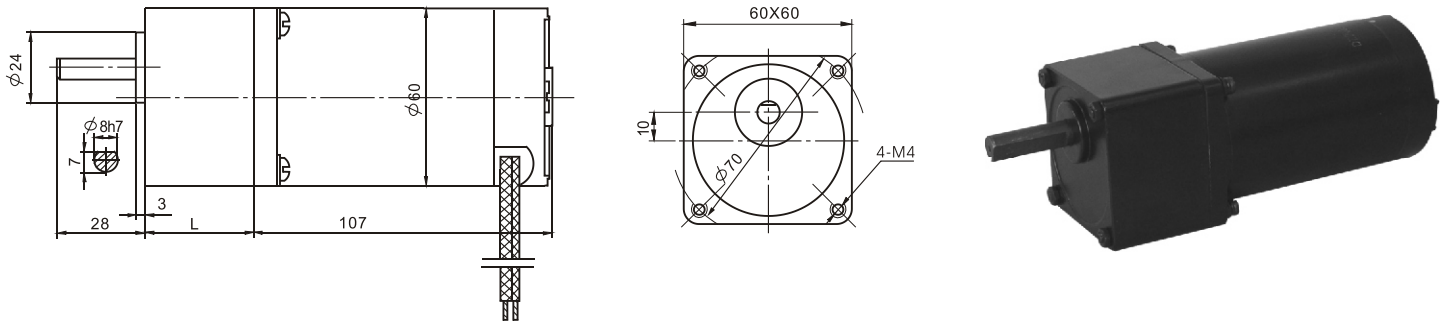

## ● 电动机主要技术参数 Motor Technical Data

电机型号 TYPE	额定电压 Rated voltage VDC	空载转速 No-load speed r/min	空载电流 No-load current A	额定转速 Rated speed r/min	额定转矩 Rated torque g.cm	输出功率 Output power W	额定电流 Rated current A	堵转转矩 Stall torque kg.cm	堵转电流 Stall current A
60105-2420	24	2000	0.32	1550	1250	20	1.6	5.5	6.0
60105-2430	24	3000	0.40	2500	1200	30	2.2	7.2	10.8

可以制造12VDC的产品，转速、转矩指标与24VDC基本一致。

We can produce products of 12VDC. The index of rotating speed and torque is consistent with 24VDC.

## ● 齿轮减速电机主要技术参数 Gear motor Technical Data

### 60JB50K/60105-2420(60ZY105-2420)

减速比	Reduction ratio	3	5	6	7.5	9	10	12.5	15	18	20	25	30	36	40	50	60
减速级数	Number of gear trains	2	2	2	2	2	2	2	2	2	3	3	3	3	3	3	3
减速器长度(L)	Length(L) mm	32	32	32	32	32	32	32	32	32	40	40	40	40	40	40	40
空载转速	No-load speed r/min	667	400	333	267	222	200	160	133	111	100	80	67	56	50	40	33
额定转速	Rated speed r/min	517	310	258	207	172	155	124	103	86	77	62	53	46	42	35	30
额定转矩	Rated torque kg.cm	3.0	5.0	6.1	7.6	9.1	10	12	15	18	18	23	25	25	25	25	25
最大瞬间允许负载	kg.cm Max. permissible load in a short time	30	30	30	30	30	30	30	30	30	50	50	50	50	50	50	50

### 60JB50K/60105-2430(60ZY105-2430)

减速比	Reduction ratio	3	5	6	7.5	9	10	12.5	15	18	20	25	30	36	40	50	60
减速级数	Number of gear trains	2	2	2	2	2	2	2	2	2	3	3	3	3	3	3	3
减速器长度(L)	Length(L) mm	32	32	32	32	32	32	32	32	32	40	40	40	40	40	40	40
空载转速	No-load speed r/min	1000	600	500	400	333	300	240	200	167	150	120	100	83	75	60	50
额定转速	Rated speed r/min	833	500	417	333	278	250	200	167	139	125	100	84	72	66	54	46
额定转矩	Rated torque kg.cm	2.9	4.8	5.8	7.3	8.7	9.7	12	14	17	17	22	25	25	25	25	25
最大瞬间允许负载	kg.cm Max. permissible load in a short time	30	30	30	30	30	30	30	30	30	50	50	50	50	50	50	50