







中山市三禮電子有限公司

3L Electronic (Zhong Shan) Co., Ltd.

URL: <http://www.3lcoil.com>

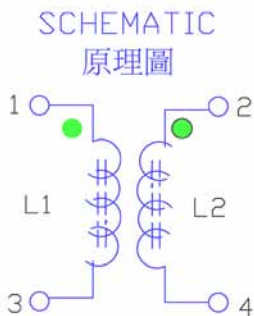
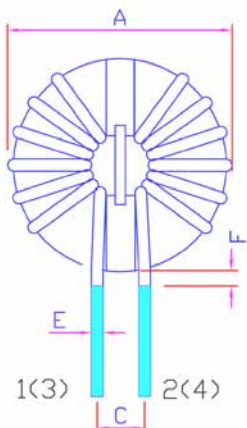
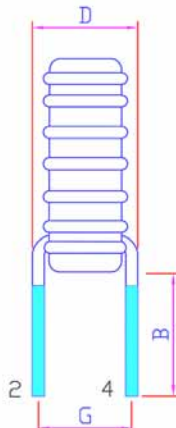

SPECIFICATION FOR APPROVAL 樣品承認書

CUSTOMER(客戶): H55 萬寶剛 Mobicon		PAGE: 1 OF 1																																		
3L P/N : LFV129-102U-3A		YOUR REF.:																																		
1.MECHANICAL DIMENSIONS (外形尺寸): DRAW NO.:LFV-ZR   		<table border="1"> <thead> <tr> <th>Item 項目</th> <th>Spec.(mm) (規格)</th> <th>Typ. (參考值)</th> </tr> </thead> <tbody> <tr><td>A</td><td>17.5 MAX</td><td>16.02</td></tr> <tr><td>B</td><td>15.0±2.0</td><td>15.1</td></tr> <tr><td>C</td><td>4.0 REF</td><td>4.15</td></tr> <tr><td>D</td><td>14.0 MAX</td><td>12.75</td></tr> <tr><td>E</td><td>0.6±0.05</td><td></td></tr> <tr><td>F</td><td>1.5 MAX</td><td></td></tr> <tr><td>G</td><td></td><td></td></tr> <tr><td>H</td><td></td><td></td></tr> <tr><td>I</td><td></td><td></td></tr> <tr><td>J</td><td></td><td></td></tr> </tbody> </table>	Item 項目	Spec.(mm) (規格)	Typ. (參考值)	A	17.5 MAX	16.02	B	15.0±2.0	15.1	C	4.0 REF	4.15	D	14.0 MAX	12.75	E	0.6±0.05		F	1.5 MAX		G			H			I			J			Marking (印字):
Item 項目	Spec.(mm) (規格)	Typ. (參考值)																																		
A	17.5 MAX	16.02																																		
B	15.0±2.0	15.1																																		
C	4.0 REF	4.15																																		
D	14.0 MAX	12.75																																		
E	0.6±0.05																																			
F	1.5 MAX																																			
G																																				
H																																				
I																																				
J																																				
2.ELECTRICAL CHARACTERISTICS (電特性要求):																																				
Item (項目)	Specifications (規格)	Typ.(參考值)	Test equipments (測試設備):																																	
L	L1=L2:1.0mH MIN	1.52mH	CHENHWA 100 LCR METER																																	
Test Freq.	@1kHz 0.25V		CHENHWA 100 LCR METER																																	
DCR	0.035ΩMAX	0.026Ω	CHENHWA 502BC OHM METER																																	
R.Current	3.0A MAX		HP4284A WITH HP42841A CURRENT SOURCE																																	
Turns	13Ts(C.W):13Ts(C.C.W)REF																																			
Ope.Temp.	-25 TO 105°C		HC-D3M TEMP. & HUMIDITY CHAMBER																																	
OTHER	*CORE与BOBIN之間 點熱熔膠固定*																																			
CUSTOMER APPROVED (客戶確認)		APPROVED(確認)	CHECKED(檢查)																																	
																																				
																																				
ISSUED DATE(出版日期): 1996/04/15 PRINT DATE(出圖日期): 2007/12/03 REV(版次):1D																																				