

Module: TB6560

3A bipolar stepper motor driver PCB for single-axis controller 10A stalls current

Discription:

Recommended supply voltage DC 10V-18V.
 6N137 high-speed light lotus root, to ensure high-speed does not stop.
 Toshiba TB6560AHQ controller, with low voltage shutdown, overheating and
 overcurrent protection circuit to ensure optimal performance.
 3A Maximum rated output current (3.5A peak).
 Suitable for 2/4 phase, 4 or 6 wire stepper motors with a maximum load current of 3A.
 Adjustable load current protection.
 Adjustable decay modes.
 Excitation modes: 1/2, 1/8, 1/16 step.
 Dimensions: 50 x 75 x 35 mm
 Weight: 83g.

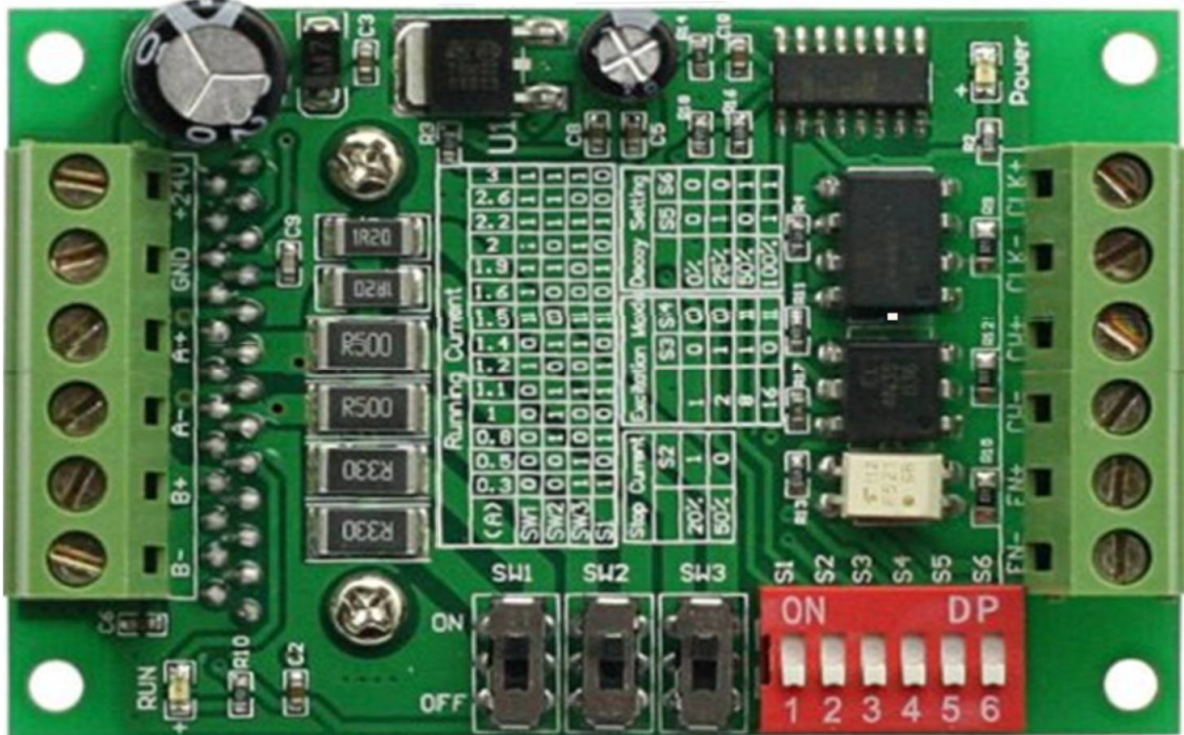

Example connections:

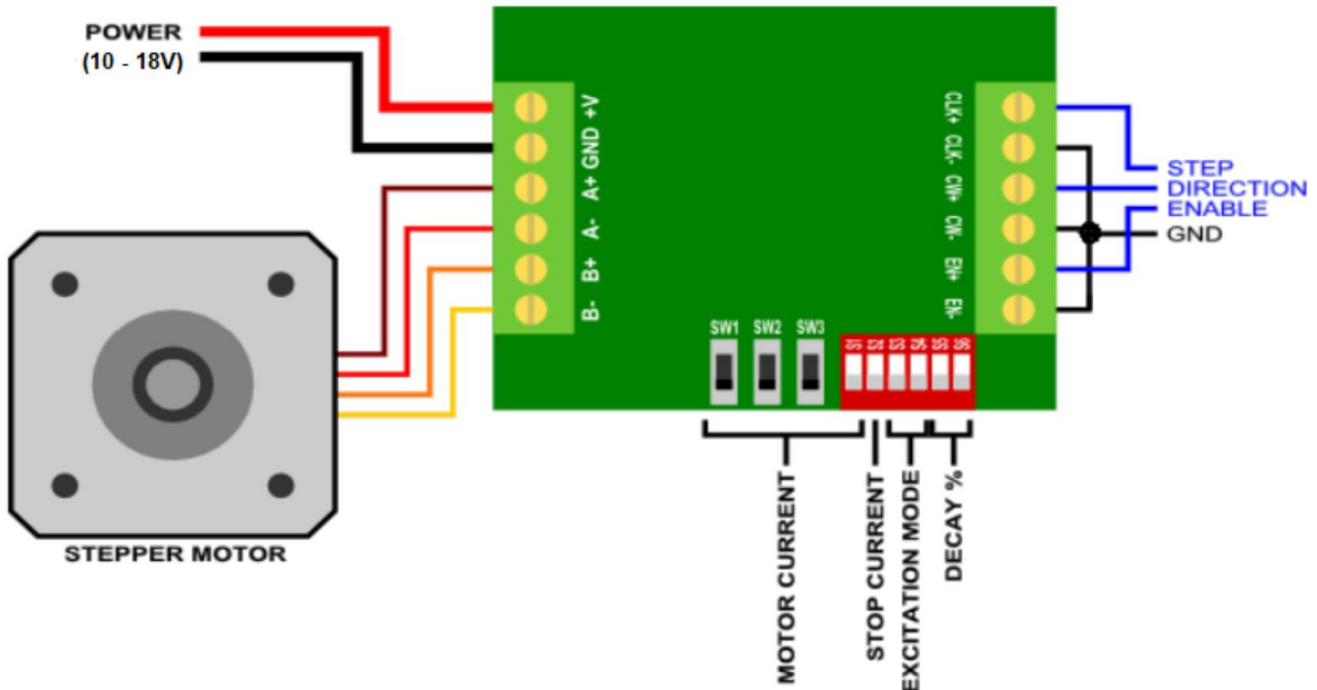
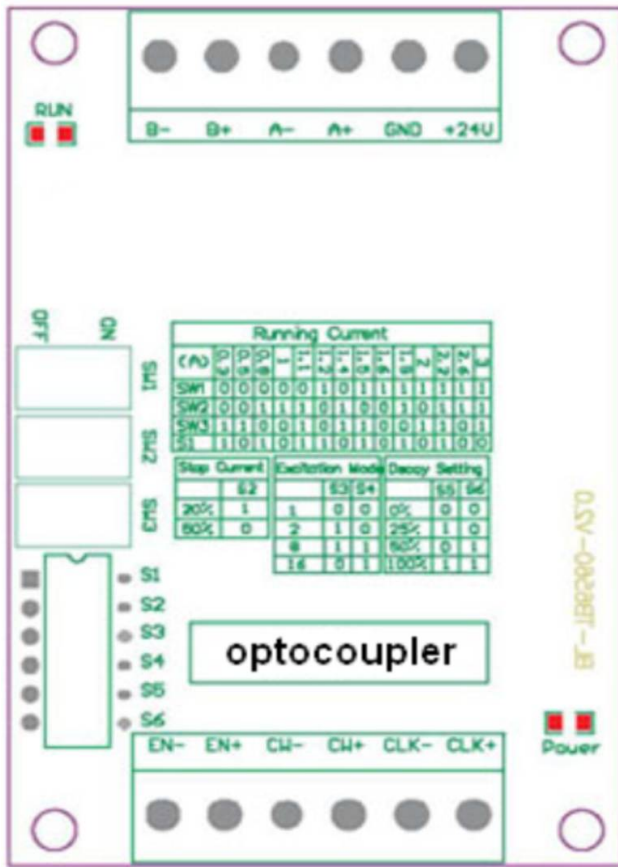

Table:



TERMINAL	CONNECTION
+24V, GND	POWER: Positive, Negative
A+, A-	MOTOR COIL: Phase A
B+, B-	MOTOR COIL: Phase B
CLK+, CLK-	Pulse for Step speed
CW+, CW-	Direction
EN+, EN-	High Enable, Low Disable

CLK-, CW- and EN- must be connected to GND

NOTE:

1. There are 6 terminal to connect the input too form part of common-cathode and common-anode.
2. The level of input pulse is 5V. If the pulse level is 12V, you need to place a series resister of 1K in line with the input signal, same as the 24V pulse level to a series 2.4K.
3. **CLK** - When the CLK recieves a pulse, the motor runs. Otherwise, the motor will enter into the set semi-flow status automatically and stop the motor.
4. **CW** - The motor forward when CW is at a low level and reverse (CCW) when high level.
5. **EN** - When the EN is low level this disables motor run. , while high level enables motor run.

Peek Current Selection														
Amps	0.3	0.5	0.8	1.0	1.1	1.2	1.4	1.5	1.6	1.9	2.0	2.2	2.6	3.0
SW1	OFF	OFF	OFF	OFF	OFF	ON	OFF	ON	ON	ON	ON	ON	ON	ON
SW2	OFF	OFF	ON	ON	ON	OFF	ON	OFF	OFF	ON	ON	OFF	ON	ON
SW3	ON	ON	OFF	OFF	ON	OFF	ON	ON	OFF	OFF	ON	ON	OFF	ON
dip S1	ON	OFF	ON	OFF	ON	ON	OFF	ON	OFF	ON	OFF	ON	OFF	OFF

Stop Current		
	20%	50%
dip S2	ON	OFF

Excitation Mode				
devison	1	1/2	1/4	1/16
dip S3	OFF	ON	ON	OFF
dip S4	OFF	OFF	ON	ON

Delay Settings				
	0%	25%	50%	100%
dip S5	OFF	ON	OFF	ON
dip S6	OFF	OFF	ON	ON

Attention:

- 1 Before switching ON the power, please double check the wiring. Incorrect wiring will probably damage the chip.
- 2 The set current should never be over the rated current of motor.

This product has been fully tested, and has been applied to the engraving machine, placement machine and other equipment, quality assurance, can be assured that use.

This module does not have any protection circuit, use must be very careful, otherwise the chip can easy be damaged. The chip is not covered by the warranty.