

Installation and Operating Instructions

Solar System Controller

ISC1520

About this manual

These operating instructions come with the product and shall be kept along it for all the life of the product for a proper installation and usage of it.

- Read these operating instructions carefully before use,
- Keep them over the entire life of the product,
- And pass them on to any future owner or user of this product.

This manual describes the installation, function, operation and maintenance of the solar system controller ISC1520.

These operating instructions are intended for end customers. A technical expert must be consulted in cases of uncertainty.

Safety

1. The solar controller may only be used in PV systems for charging and controlling Lead-Acid batteries.
2. No energy source other than a solar generator may be connected to the solar charge controller.
3. Do not connect any defective or damaged measuring equipment.
4. Follow the general and national safety and accident prevention regulation.
5. Never alter or remove the factory plates and identification labels.
6. Keep children away from PV systems.
7. Never open the device.
8. One set solar module can connect with one controller only.
9. Never touch bare cables ends.

Other risks

Danger of fire and explosion

- ◆ Do not use the solar charge controller in dusty environments, in the vicinity of solvents or where inflammable gases and vapors can occur.
- ◆ No open fires, flames or sparks in the vicinity of the batteries.
- ◆ Ensure that the room is adequately ventilated.
- ◆ Check the charging process regularly.
- ◆ Follow the charging instructions of the battery manufacturer.

Battery acid

- ◆ Acid splashes on skin or clothing should be immediately treated with soap suds and rinsed with plenty of water.
- ◆ If acid splashes into the eyes, immediately rinse with plenty of water. Seek medical advice.

Fault behaviour

Operating the solar charge controller is dangerous in the following situations:

- ◆ The solar charge controller does not appear to function at all.
- ◆ The solar charge controller or connected cables are visibly damaged.
- ◆ Emission of smoke or fluid penetration.
- ◆ When parts are loose.

In these cases immediately remove the solar charge controller from the solar panels and battery.

Function

This solar system controller is designed to

- ◆ Monitor the state of charge of the battery;
- ◆ Controls the charging process,
- ◆ Control the connection/disconnection of loads,
- ◆ Make sure Solar system works at proper condition.
- ◆ Manual load switch with automatic re-start.

Operating the controller

The display shows a variety of system data by symbols and digits. Both buttons control all settings and display windows.

1. Display and operation elements

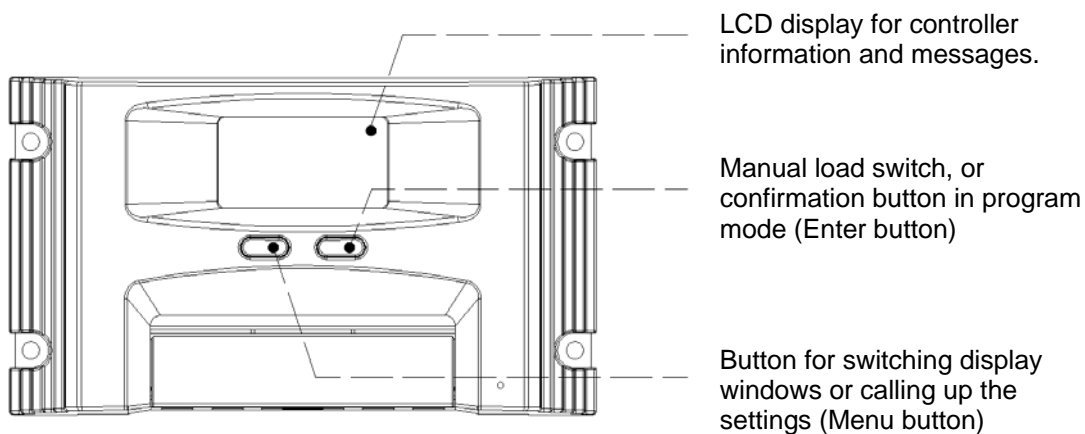

2. Display window

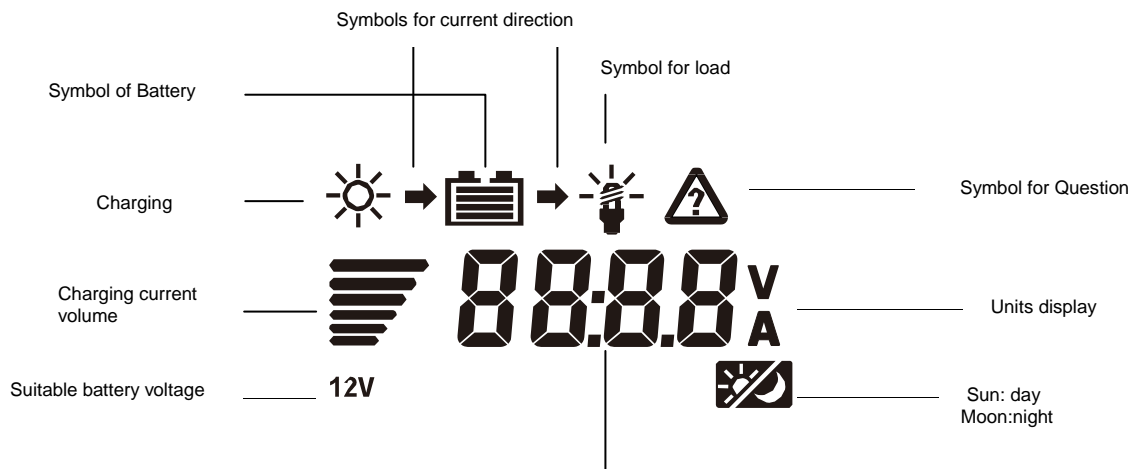

4-Segment display for text and figures

Change the display windows with the left button;

1. The default window will show like below, battery voltage/capacity volume of the battery.

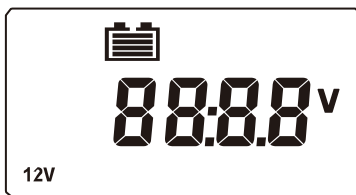

2. Press "menu" button once to check charging current.



3. Press "menu" button again to display the load current.



4. At default display mode, press “enter” button to control the load On or Off.

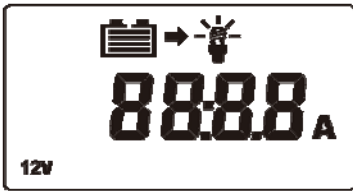

5. If solar module can not provide current or the current is less than 1Amp, last 5 minutes more, controller will switch to Night mode.

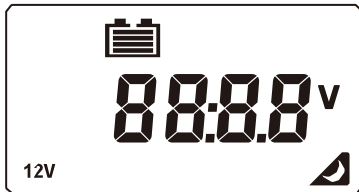

6. When the output current is less than 1Amp, the LCD will always show C1.0A.

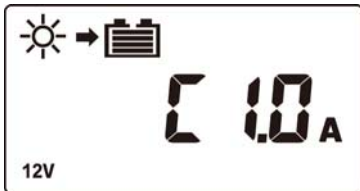

Function Introduction

1. PWM Charge control

Depending on the actual battery level, various charging procedures, float charging, boost charging and equalization charging are automatically performed. The final charging voltage is temperature compensated.

2. Deep discharging protection

If the battery falls below a specified charge level or battery voltage, the load output is disconnected and the discharge of the battery is prevented. The set points of the deep discharging protection are predefined and cannot be reset.

Installation

- ◆ Only install the controller near the battery on a suitable surface. This surface should be solid, stable, even, dry and nonflammable.
- ◆ The battery cable should be as short as possible(1-2m) and have a suitable cable diameter size to minimize loss.(Recommended cable is 25 square mm and 2 m length)
- ◆ Do not assemble this unit outdoors, the unit should be installed so that it is protected against humidity, dripping, rainwater as well as direct and indirect warming (sunlight)
- ◆ To ensure the air circulation for cooling, an area of 15cm on each side of the unit must be kept free.
- ◆ The LCD display should be protected against UV rays(e.g. sunlight). Long time exposure to UV rays can permanently discolor the LCD
- ◆ The solar charge controller may only be connected to the local loads and the battery by trained personnel and in accordance with the applicable regulations.
- ◆ Follow the installation and operating instructions for all components of the PV system.
- ◆ Ensure that no cables are damaged.
- ◆ Ensure that polarity of solar panel/battery/load is connected in proper way and use only insulated tools.

1. Mounting the solar charge controller
 - 1.1 Do not mount the solar charge controller outdoors or in wet rooms
 - 1.2 Do not subject the solar charge controller to direct sunshine or other source of heat.
 - 1.3 Protect the solar charge controller from dirt and moisture.
 - 1.4 Maintain a minimum clearance of 10cm below and around the device to ensure unhindered air circulation
 - 1.5 Mount the solar controller as close as possible to the batteries (with a safety clearance of at least 35cm).

2. Fix the solar charge controller

- 2.1 Mark the position of controller fix holes on the walls;
- 2.2 Drill 4pcs Ø6mm holes and insert dowels.
- 2.3 Fix the controller to the wall with the cable openings facing downwards, using 4 oval head screws M4x35(DIN 7996).

Grounding

Grounding the unit is not technically required when installing a stand alone solar system. However, one ground is possible for the PV array to be positive grounding.

This unit can ground positive only.

Install the solar system and operating mode

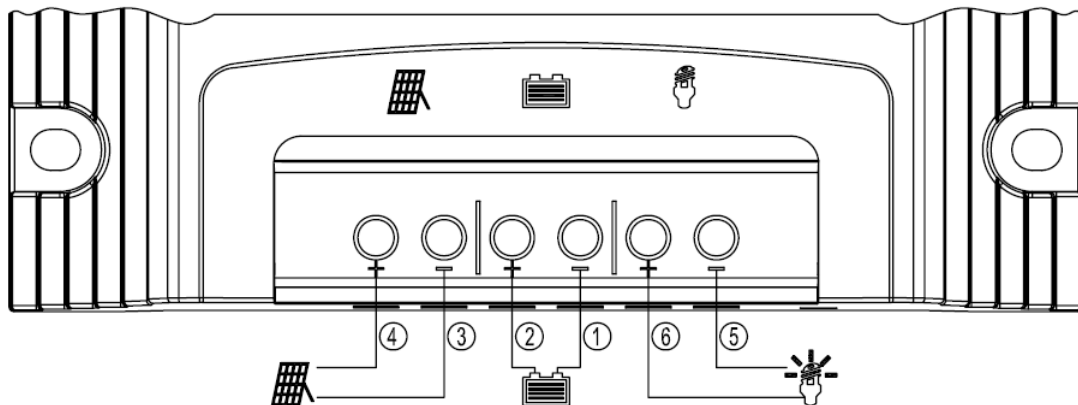

- Connect the wires in the sequence from 1 to 6 according the above diagram; when Disconnect the wires in the REVERSE sequence from 6 to 1 according the above diagram.
- Use with 12V batteries only.
- Never exceed the nominal ratings (see below technical data for reference).
- Suggested cable length, 10m solar panel connection cable/2m battery connection cable/5m load connection cable.

TECHNICAL INFORMATION

Max. Input Current	15A _{dc}
Max. Input Voltage (V _{oc})	29V _{dc}
Max. Load Current	15A _{dc}
Over Charge Voltage	14.4V _{dc} ±2%
Over Discharge Voltage	11.0V _{dc} ±2%
Output Voltage	12V _{dc}
Typical Idle Consumption	<20mA _{dc}
Operating temperature	-20°C/+50°C

Charging Curve

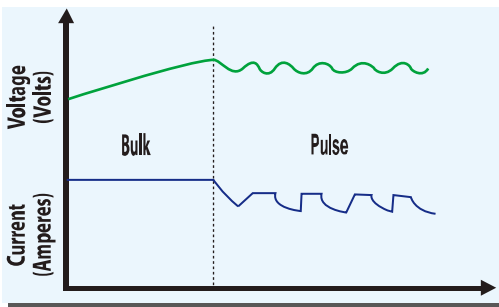

Bulk: This is the first charging stage where the battery at low charge stage, typically 10%, receives the majority of its charge. During this stage the battery brought to about 95% of its charger getting 100% of the available solar power.

Pulse (Maintenance): At the end of bulk stage, typically when the battery reach 14.4 Volts, a maintenance mode starts where the battery voltage can float between an high and low value fixed by the controller. These values are temperature compensated in order to keep the battery at 100% charge stage in any condition.

Protection functions

- ◆ Overcharge protection
- ◆ Deep discharge protection
- ◆ Battery under-voltage protection
- ◆ Solar panel reverse current protection

The following installation faults do not destroy the controller. After correcting fault, the device will continue to operate correctly:

- ◆ Overcharge protection
- ◆ Deep discharge protection
- ◆ Reverse polarity protection of load, panel and battery
- ◆ Automatic electronic fuse
- ◆ Short circuit protection of load and panel
- ◆ Over voltage protection at panel input
- ◆ Open circuit protection without battery
- ◆ Reverse current protection at night
- ◆ Overload protection
- ◆ Battery over voltage shutdown

Maintenance

The controller is maintenance-free. We strongly suggest that all components of the PV system must be checked at least annually,

- ◆ Ensure adequate ventilation of the cooling element
- ◆ Check the cable strain relief
- ◆ Check that all cable connections are secure
- ◆ Tighten screws if necessary
- ◆ Terminal corrosion

Error Messages

Caution! Please do not open the controller or attempt to replace components when troubleshooting. Improper maintenance can be hazardous to the user and the system.

If the controller detects errors or unauthorized operating states, it shows error codes on the display. Error codes can generally be differentiated, whether there is a temporary malfunction, e.g. regulator overload or a more serious system error that can be remedied by appropriate external measures.

Since not all errors can be simultaneously displayed, the error with the highest error number (priority) is displayed. If several errors are present, the second error code is displayed after remedying the more significant error.

The following meaning is assigned to the different error codes:

1.



Meaning: Battery polarity reverse warning

Remedy: Reconnect cable of battery in proper way.

2.



Meaning: Battery is wrong.

Remedy: Check battery voltage it might be too low or too high, possibly recharge battery manually. If battery can't be recharged, it might be deep-discharged. Consumer needs to change a new battery.

3.



Meaning: Module current too high.

Remedy: Reduce the load current or module power.

4.



Meaning: Over current at the load output.

E4

Remedy: Reduce the current of load.

Remark: If the current is reduced the controller does not work.

If either of the below situations arise, the unit has E4 problem:

1) If the load does not connect – Press the “Enter” button, LCD shows E4.

2) If the load is over 50W - Press the “Enter” button, load current will show 0.00A.

Please try to reset the unit by disconnecting all the connections, then hold on to the “Menu” button and reconnect the battery connections to its +ve and –ve ports.

5.



Meaning: Solar module polarity reverses.

E5

Mark: This will display only 30 seconds.

Remedy: Check connection of solar module and connect it in proper way.

6.

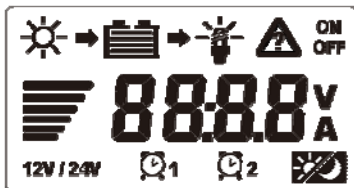

Meaning: Battery is open circuit or short circuit.

Mark: The display keeps blinking with 8888 and all the symbols.

Remedy: Check connection between Solar Charger Controller and the battery, and make sure they are in good connection.

The Leading Edge in Solar Technology



Waste electrical products should not be disposed of with household waste
Please recycle where facilities exist
Check with your local authority or retailer for recycling advice

Specifications are subject to change without prior notice
Copyright reserved by ProVista Technology Limited
Version of Instruction manual 1.2

FOR TECHNICAL
ADVICE OR HELP
PLEASE CONTACT :

ProVista[™]
TECHNOLOGY

Tel: 852-2330 8842

Fax: 852-2330 8843

Email: sales@provistahk.com

Website: www.provistahk.com