



CLOVER DISPLAY LTD.

LCD MODULE SPECIFICATION

Model: CV9162E - _ _ - _ _ - _ _ - _ _

Revision	10
Engineering	Timmy Kwan
Date	11 August 2010
Our Reference	9016

ADDRESS : ROOM 1006, 10/F WESTIN CENTRE, 26 HUNG TO ROAD, KWUN TONG,
KOWLOON, HONG KONG.

TEL : (852) 2341 3238 (SALES OFFICE) (852) 2342 8228 (GENERAL OFFICE)

FAX : (852) 2357 4237 (SALES OFFICE) (852) 2341 8785 (GENERAL OFFICE)

E-MAIL : cdl@cloverdisplay.com

URL : <http://www.cloverdisplay.com>

MODE OF DISPLAY**Display mode**

- TN positive
 TN negative
 STN : Yellow green
 Grey
 Blue (negative)
 FSTN positive
 FSTN negative

Display condition

- Reflective type
 Transflective type
 Transmissive type
 Others

Viewing direction

- 6 O' clock
 12 O' clock
 3 O' clock
 9 O' clock

LCD MODULE NUMBER NOTATION:

CV9162E- N N - S R - N 6 - T
 | | | | | | | |
 (1) (2) (3) (4) (5) (6) (7) (8)

*(1)---Model number of standard LCD Modules

*(2)---Backlight type

- N – No backlight
 E – EL backlight
 L – Side-lited LED backlight
 M – Array LED backlight
 C – CCFL

*(3)---Backlight color

- N – No backlight
 A – Amber
 B – Blue
 O – Orange
 W – White
 Y – Yellow green

*(4)---Display mode

- T – TN
 V – TN (Negative)
 S – STN Yellow green
 G – STN Grey
 B – STN Blue (Negative)
 F – FSTN
 N – FSTN (Negative)

*(5)---Rear polarizer type

- R – Reflective
 F – Transflective
 T – Transmissive

*(6)---Temperature range

- N – Normal
 W – Extended

*(7)---Viewing direction

- 6 – 6 O'clock
 2 – 12 O'clock
 3 – 3 O'clock
 9 – 9 O'clock

*(8)---Special code for other requirements
 (Can be omitted if not used)

GENERAL DESCRIPTION

Display mode : 16 characters x 2 lines, COG LCD module

Interface : 4-bit parallel

Driving method : 1/16 duty, 1/5 bias

Controller IC : Novatek NT7603 or equivalent

For the detailed information, please refer to the IC specifications.

MECHANICAL DIMENSIONS

Item	Dimension	Unit	Item	Dimension	Unit
Outline Dimension			Character Size	2.24(L)x3.55(W)	mm
No Backlight (N)	48.2(L)x21.0(W)x2.9(H)	mm	Character Pitch	2.64(L)x3.95(W)	mm
LED Side Backlight (L)	48.2(L)x21.0(W)x6.8(H)	mm	Dot Size	0.4(L)x0.4(W)	mm
Viewing Area	43.9(L)x10.0(W)	mm	—	—	—

CONNECTOR PIN ASSIGNMENT

Pin No.	Symbol	Function	Pin No.	Symbol	Function
1	GND	Ground	7	DB4	Data bus line
2	VO	Input Voltage for LCD	8	DB5	
3	VDD	Supply Voltage for Logic	9	DB6	
4	RS	Register Select	10	DB7	
5	RW	Read / Write Select	11	A	Supply Voltage for backlight (+VE)*
6	E	Chip Enable	12	K	Supply Voltage for backlight (-VE)*

(*) Note: Pin 11, 12 are for side-lited LED backlight revision only.

COUNTER DRAWING OF MODULE DIMENSION

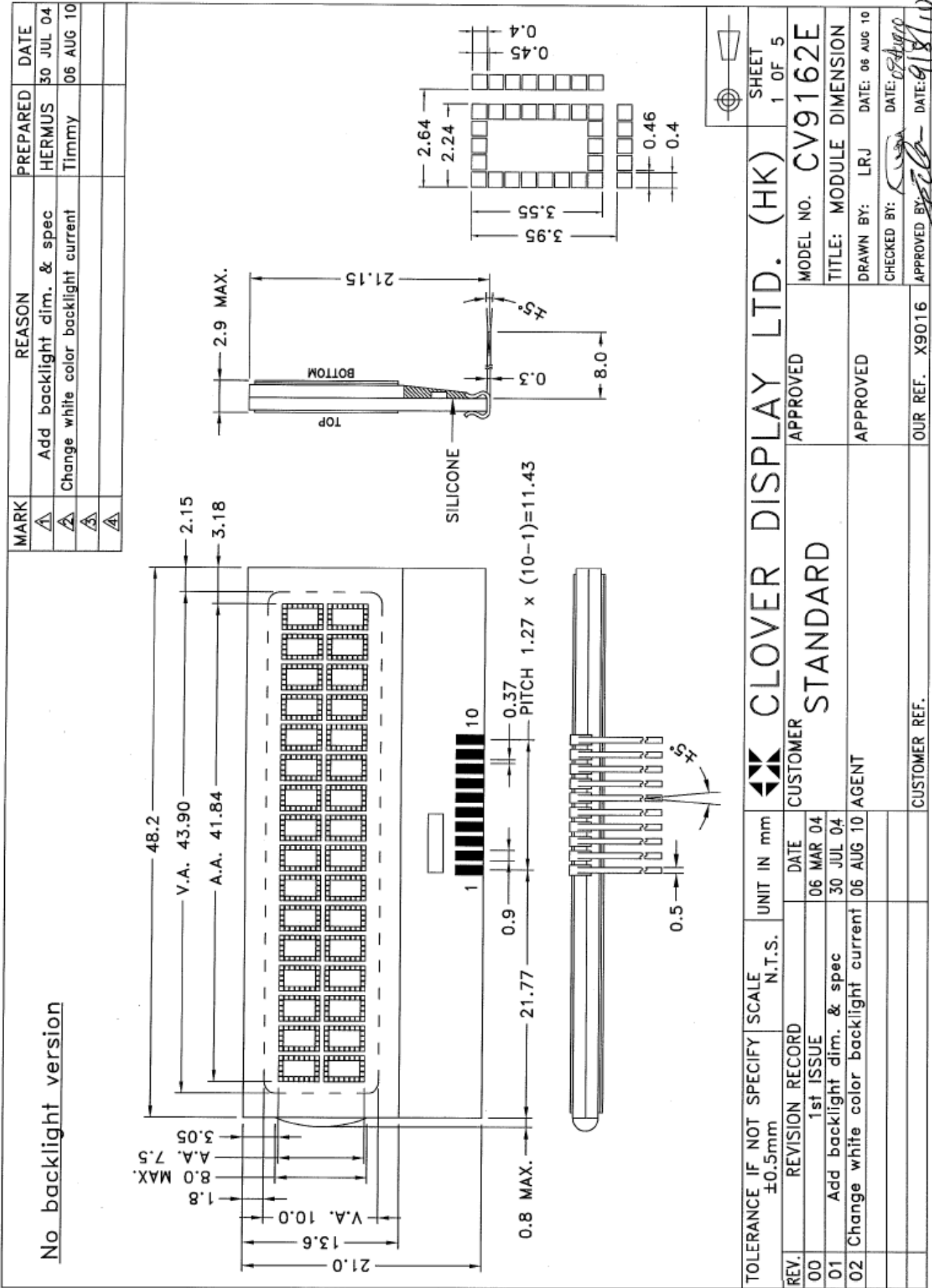

Yellow green color side lited backlight

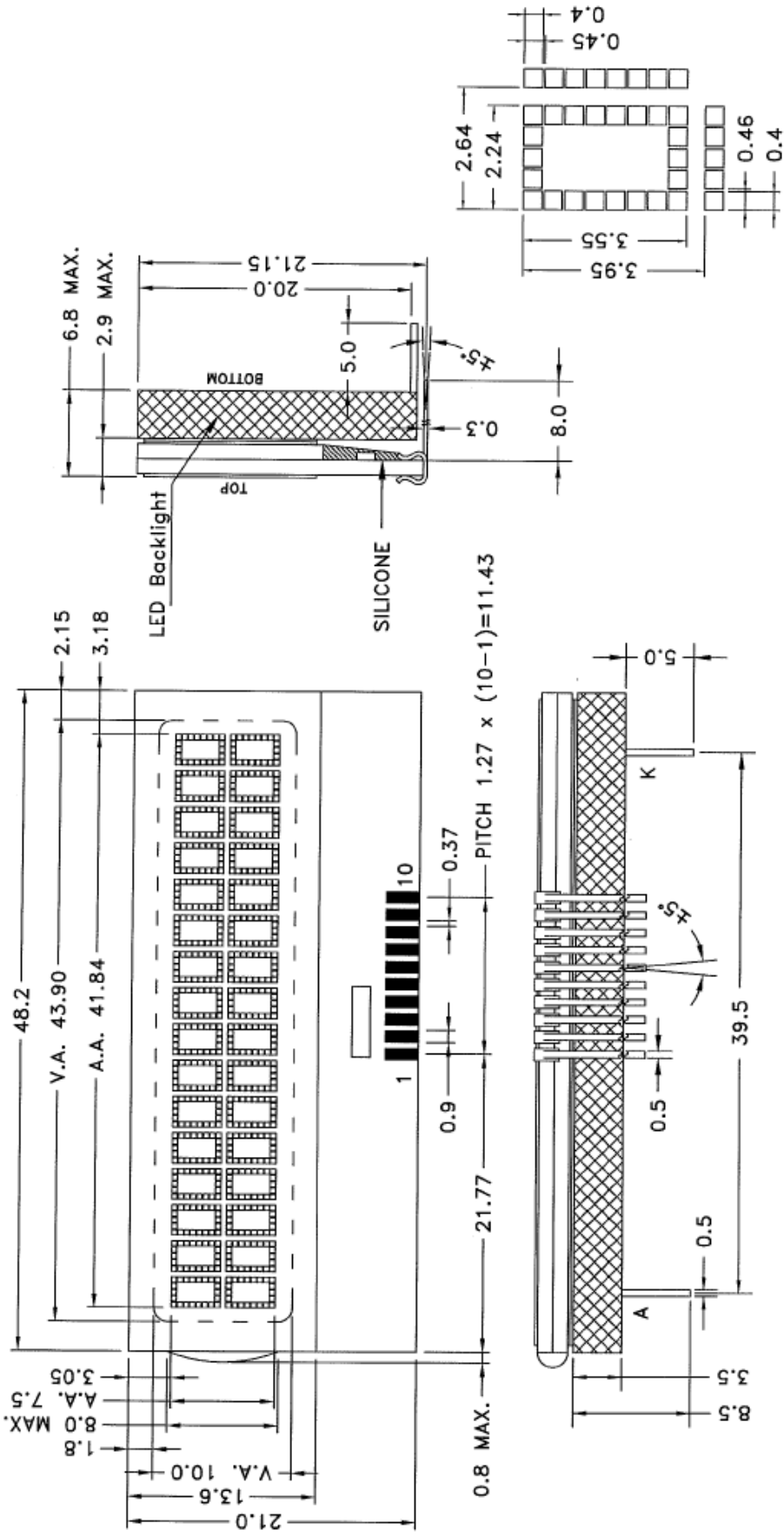

TOLERANCE IF NOT SPECIFY SCALE $\pm 0.5\text{mm}$		UNIT IN mm		SHEET 2 OF 5
REV.	REVISION RECORD	N.T.S.	DATE	
00	1st ISSUE		06 MAR 04	MODEL NO. CV9162E
01	Add backlight dim. & spec		30 JUL 04	
02	Change white color backlight current		06 AUG 10	DRAWN BY: LRJ
				DATE: 06 AUG 10
				CHECKED BY: <i>[Signature]</i>
				DATE: 09 Aug 10
				APPROVED BY: <i>[Signature]</i>
				DATE: 09 10
	CUSTOMER REF.	CUSTOMER REF.	OUR REF. X9016	APPROVED
				APPROVED
				STANDARD
				APPROVED

White / Blue color side lited backlight 

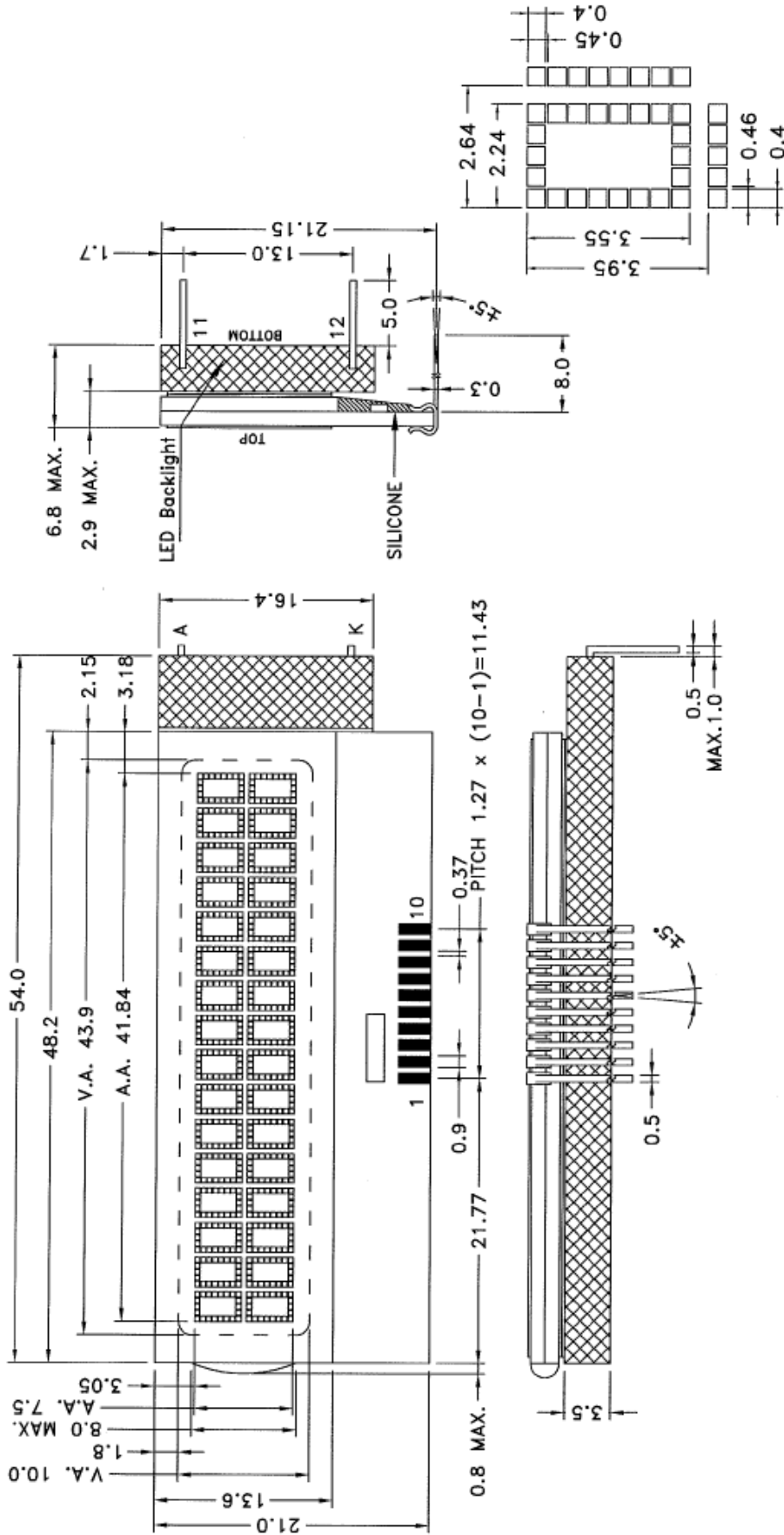

TOLERANCE IF NOT SPECIFY SCALE ±0.5mm		SCALE N.T.S.	UNIT IN mm	CLOVER DISPLAY LTD. (HK)		SHEET 3 OF 5
REV.	REVISION RECORD	DATE	CUSTOMER	APPROVED	MODEL NO.	CV9162E
00	1st ISSUE	06 MAR 04	STANDARD	APPROVED	TITLE:	MODULE DIMENSION
01	Add backlight dim. & spec	30 JUL 04			DRAWN BY:	LRJ
02	Change white color backlight current	06 AUG 10	AGENT	APPROVED	CHECKED BY:	DATE: 07 Aug 10
			CUSTOMER REF.	OUR REF.	APPROVED BY:	DATE: 07 Aug 10
				X9016		

COUNTER DRAWING OF PIN OUT & BLOCK DIAGRAM

PIN NO.	SYMBOL	FUNCTION
1	GND	Ground
2	V5	Input voltage for LCD
3	VDD	Supply voltage for logic
4	RS	Register select
5	RW	Read / Write select
6	E	Chip enable
7	DB4	Data bus line
8	DB5	
9	DB6	
10	DB7	
*11	A	Supply voltage for backlight (+VE)
*12	K	Supply voltage for backlight (-VE)

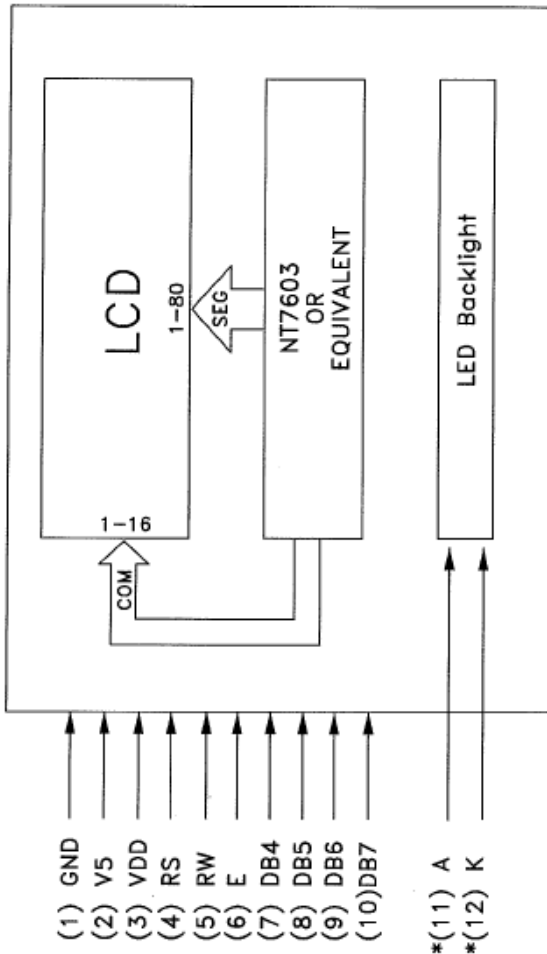

Note(*): Pin11,12 are used for side-lited backlight versions only.

TOLERANCE IF NOT SPECIFY ±0.5mm		SCALE N.T.S.	UNIT IN mm	CLOVER DISPLAY LTD. (HK)		SHEET 4 OF 5
REV.	REVISION RECORD	DATE	CUSTOMER	APPROVED	MODEL NO.	CV9162E
00	1st ISSUE	06 MAR 04	STANDARD		TITLE:	PIN OUT & BLOCK DIAGRAM
01	Add backlight dim. & spec	30 JUL 04		APPROVED	DRAWN BY:	LRJ
02	Change white color backlight current	06 AUG 10	AGENT		CHECKED BY:	DATE: 06 AUG 10
					APPROVED BY:	DATE: 09/06/10
			CUSTOMER REF.	OUR REF.	X9016	

ELECTRICAL CHARACTERISTICS

Conditions: VSS=0V, @Ta=25°C

Item	Symbol	MIN.	TYP.	MAX.	Unit
Supply Voltage	VDD	4.75	5.00	5.25	V
Supply Current	IDD	—	1.1	1.6	mA
Input Voltage for LCD (*)	VO	0.3	0.5	0.7	V
“H”Level Input Voltage	VIH	2.2	—	VDD	V
“L”Level Input Voltage	VIL	0.0	—	0.6	V

Note (*): There is tolerance in optimum LCD driving voltage during production and it will be within the specified range.

Side Backlight

Constant voltage driving:

Item	Symbol	MIN.	TYP.	MAX.	Unit	Condition
Blue Backlight current	IBL	16	18	20	mA	VBL =3.5V
White Backlight current	IBL	12	14	16	mA	VBL =3.5V

Constant current driving:

Item	Symbol	MIN.	TYP.	MAX.	Unit	Condition
Yellow Green Backlight voltage	VBL	—	2.0	2.4	V	IBL = 60 mA

ABSOLUTE MAXIMUM RATINGS

Please make sure not to exceed the following maximum rating values under the worst application conditions

Item	Symbol	Rating (for normal temperature)	Rating (for wide temperature)	Unit
Supply Voltage	VDD	7	7	V
Input Voltage	VT	-0.3 to VDD +0.3	-0.3 to VDD +0.3	V
Operating Temperature	Topr	0 to 50	-20 to 70	°C
Storage Temperature	Tstg	-10 to 60	-30 to 80	°C

Instruction Set

Instruction	Code										Function	Execution time (max) (f _{osc} = 250KHz)	
	RS	RW	DB7	DB6	DB5	DB4	DB3	DB2	DB1	DB0			
Display Clear	0	0	0	0	0	0	0	0	0	1	Clear entire display area.	1.64ms	
Display/ Cursor Home	0	0	0	0	0	0	0	0	1	*	Restore display from shift and load address counter with DD RAM address 00H.	1.64ms	
Entry Mode Set	0	0	0	0	0	0	0	1	I/D	S	Specify direction of cursor movement and display shift mode. This operation takes place after each data transfer (read/write).	40μs	
Display ON/OFF	0	0	0	0	0	0	1	D	C	B	Specify activation of display (D) cursor (C) and blinking of character at cursor position (B).	40μs	
Display/ Cursor Shift	0	0	0	0	0	1	S/C	R/L	*	*	Shift display or move cursor.	40μs	
Function Set	0	0	0	0	1	DL	N	F	*	*	Set interface data length (DL), number of display line (N), and character font (F).	40μs	
RAM Address Set	0	0	0	1	ACG							Load the address counter with a CG RAM address. Subsequent data access is for CG RAM data.	40μs
DD RAM Address Set	0	0	1	ADD							Load the address counter with a DD RAM address. Subsequent data access is for DD RAM data.	40μs	
Busy Flag/ Address Counter Read	0	1	AC									Read Busy Flag (BF) and contents of Address Counter (AC).	40μs
CG RAM/ DD RAM Data Write	1	0	Write data									Write data to CG RAM or DD RAM.	40μs
CG RAM/ DD RAM Data Read	1	1	Read data									Read data from CG RAM or DD RAM.	40μs
	I/D = 1 : Increment S = 1 : Display Shift On D = 1 : Display On C = 1 : Cursor Display On B = 1 : Cursor Blink On S/C = 1 : Shift Display R/L = 1 : Shift Right DL = 1 : 8-Bit N = 1 : Dual Line F = 1 : 5x10 dots BF = 1 : Internal Operation BF = 0 : Ready for Instruction I/D = 0 : Decrement S/C = 0 : Move Cursor R/L = 0 : Shift Left DL = 0 : 4-Bit N = 0 : Signal Line F = 0 : 5x8 dots										DD RAM : Display Data RAM CG RAM : Character Generator RAM ACG : Character Generator RAM Address ADD : Display Data RAM Address AC : Address Counter		

Note 1: Symbol "*" signifies an insignificant bit (disregard).
 Note 2: Correct input value for "N" is predetermined for each model.

DISPLAY DD RAM AND CHARACTER POSITION

16x2, 1/16 DUTY CYCLE

	1	2									16	DISPLAY POSITION		
line 1	00	01	•	•	•	•	•	•	•	•	•	•	0F	DD RAM ADDRESS
line 2	40	41	•	•	•	•	•	•	•	•	•	•	4F	

Power Supply Conditions Using Internal Reset Circuit

Symbol	Parameter	Min.	Typ.	Max.	Unit	Conditions
t _{RON}	Power Supply Rise Time	0.1	-	10	ms	Figure 3
t _{OFF}	Power Supply OFF Time	1	-	-	ms	Figure 3

Write Operation

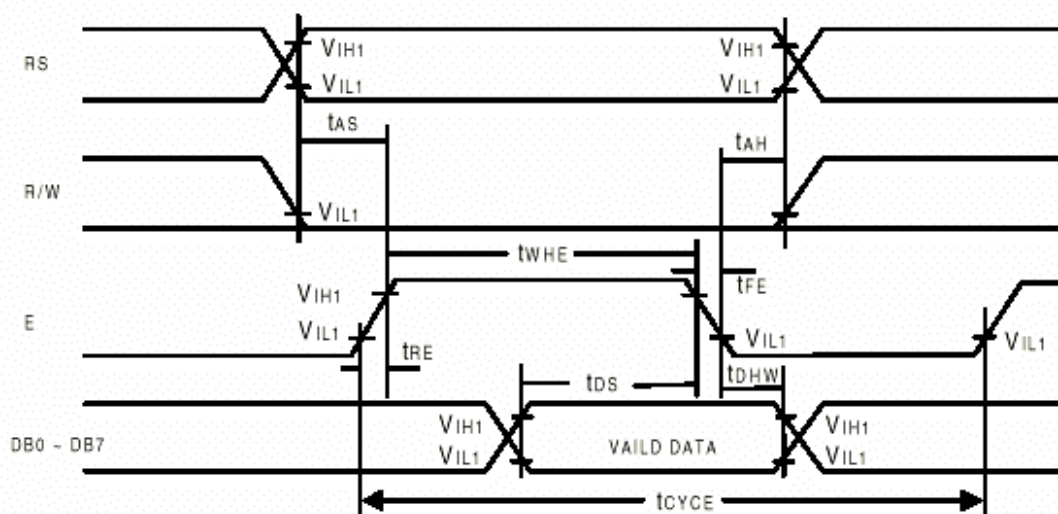

Figure 2. Bus Write Operation Sequence
(Writing out data from NT7603 to MPU)

Read Operation

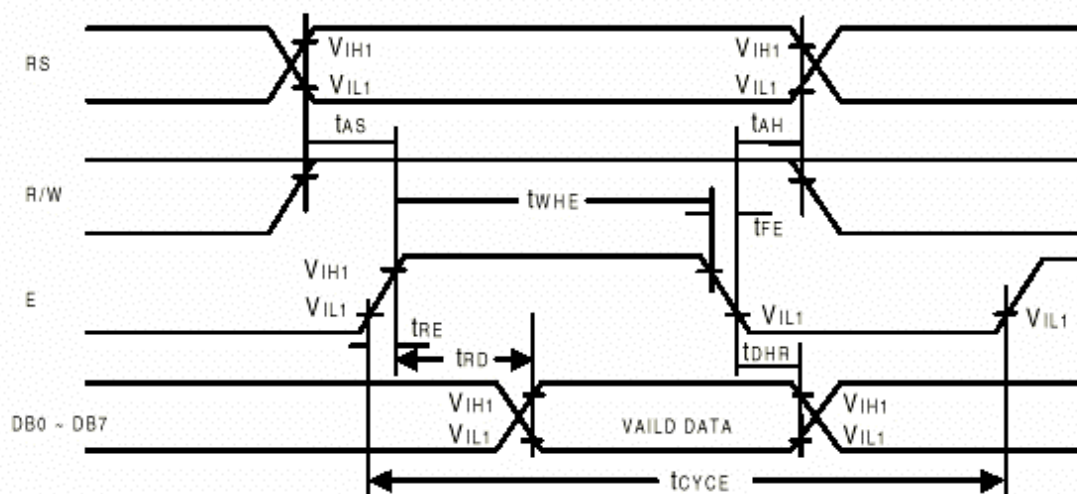

Figure 1. Bus Read Operation Sequence
(Reading out data from NT7603 to MPU)

ELECTRO-OPTICAL CHARACTERISTICS

MEASURING CONDITION: POWER SUPPLY = $V_{OP} / 64 \text{ Hz}$
 TEMPERATURE = $23 \pm 5 \text{ }^\circ\text{C}$
 RELATIVE HUMIDITY = $60 \pm 20 \%$

ITEM	SYMBOL	UNIT	TYP. STN
RESPONSE TIME	Ton	ms	150
	Toff	ms	190
CONTRAST RATIO	Cr	-	15
	V3:00	°	45
VIEWING ANGLE	V6:00	°	70
	(6 O'clock) V9:00	°	45
	Cr ≥ 2 V12:00	°	60

THE ELECTRO-OPTICAL CHARACTERISTICS ARE MEASURED VALUE BUT NOT GUARANTEED ONES.

RELIABILITY OF LCD MODULE

ITEM	TEST CONDITION FOR NORMAL TEMPERATURE	TEST CONDITION FOR WIDE TEMPERATURE	TIME
High temperature operating	50°C	70°C	240 hours
Low temperature operating	0°C	-20°C	240 hours
High temperature storage	60°C	80°C	240 hours
Low temperature storage	-10°C	-30°C	240 hours
Temperature-humidity storage	40°C 90% R.H.	60°C 90% R.H.	96 hours
Temperature cycling	-10°C to 60°C 30 Min Dwell	-30°C to 80°C 30 Min Dwell	5 cycle
Vibration Test at LCM Level	Freq 10-55 Hz Sweep rate: 10-55-10 at 1 min Sweep mode Linear Displacement: 2 mm p-p 1 Hour each for X, Y, Z	Freq 10-55 Hz Sweep rate: 10-55-10 at 1 min Sweep mode Linear Displacement: 2 mm p-p 1 Hour each for X, Y, Z	—

SAMPLING METHOD

SAMPLING PLAN: MIL-STD 105E
 CLASS OF AQL: LEVEL II/ SINGLE SAMPLING
 MAJOR-0.65% MINOR – 1.5%

QUALITY STANDARD

DEFECT	CRITERIA	TYPE	FIGURE
SHORT CIRCUIT	-	MAJOR	-
MISSING SEGMENT	-	MAJOR	-
UNEVEN / POOR CONTRAST	-	MAJOR	-
CROSS TALK	-	MAJOR	-
PIN HOLE	$MAX(a,b) \leq 1/4 W$	MINOR	1
EXCESS SEGMENT	$MAX(c,d) \leq 1/4 T$	MINOR	1
BUBBLES	$d^* \geq 0.2$ QTY=0	MINOR	2
BLACKS SPOTS	$d \leq 0.3$ N.A.** $0.3 < d \leq 0.4$ QTY \leq 1 $0.4 < d$ QTY=0	MINOR	2
LINE SCRATCHES	$x \geq 0.7$ $y \geq 0.05$ QTY=0	MINOR	3
BLACK LINE	$x \geq 0.7$ $y \geq 0.05$ QTY=0	MINOR	3

*d = MAX (d₁,d₂)

** N. A . = NOT APPLICABLE

DEFECT TABLE : B

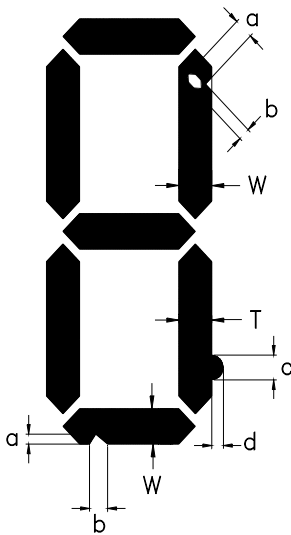
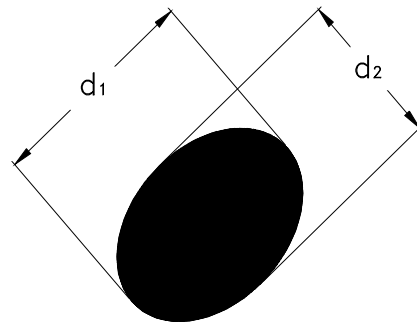
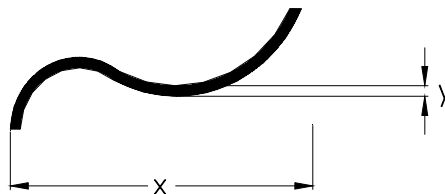

fig . 1



POLARIZER BUBBLES / SPOTS
fig . 2



LINE SCRATCHES / BLACK LINE
fig . 3

QUALITY STANDARD (CONT .)

DEFECT		CRITERIA	TYPE	FIGURE
	CONTACT EDGE	$e \leq 1/2T$ $f \leq 1/3W$ $g \leq 3.5$		4
CHIPS	BOTTOM GLASS	$p \leq 1.0$ $q \leq 3.5$ $r \leq 1/2T$	MINOR	4
	CORNER	$a \leq 1.5$ $b \leq W$		4
	TOP GLASS	$a \leq 3.0$ $b \leq 1/3T$ $c \leq 1/2W$		5
GLASS PROTRUSION		$a \leq 1/4 W$	MINOR	6
RAINBOW		-	MINOR	-

UNLESS STATE OTHERWISE , ALL UNIT ARE IN MILLIMETER .

DEFECT TABLE : B

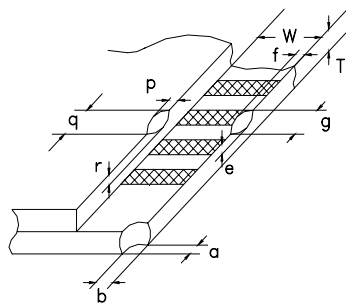

fig . 4

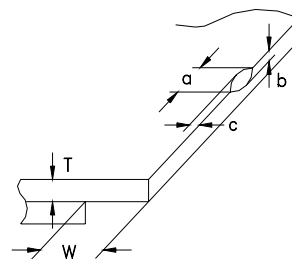

fig . 5

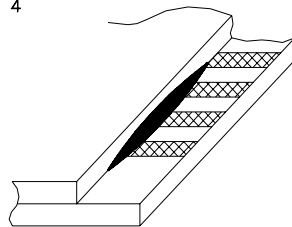
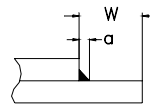

fig . 6



HANDLING PRECAUTIONS

(1) CAUTION OF LCD HANDLING & CLEANING

The polarizing plate on the surface of the panel is made from organic substances. Be very careful for chemicals not to touch the plate or it leads the polarizing plate to deteriorate.

If the use of a chemical is unavoidable, wipe the panel lightly with soft materials, such as gauze and absorbent cotton, soaked in a solvent.

*Usable solvent: Alcohol (ethanol, IPA and the like)

*Appropriate solvent: Ketones, ethyl alcohol

Avoid wiping with a dry cloth, since it could damage the surface of the polarizing plate and others.

Do not expose to direct sunlight or fluorescent light for a long time

(2) CAUTION AGAINST STATIC CHARGE

The LCD modules use CMOS LSI drivers, so customers are recommended that any unused input terminal would be connected to V_{DD} or V_{SS} , do not input any signals before power is turned on, and ground your body, work/assembly areas, assembly equipment to protect against static electricity.

(3) ESD PRECAUTION

Inputs and outputs are protected against electrostatic discharge in normal handling. However, to be totally safe, it is recommended to take normal precautions appropriate to handling LCM module. For example: product surface grounding.

Always take ESD precaution when handling the *LCD Module*. Components are exposed for direct finger touches and can be damaged unless ESD precaution is taken.

(4) PACKAGING

Avoid intense shock and falls from a height and do not operate or store them exposed to direct sunshine or high temperature/humidity for long periods.

(5) CAUTION FOR OPERATION

The viewing angle can be adjusted by varying the LCD driving voltage V_O .

Driving voltage should be kept within specified range, excess voltage shortens display life.

Response time increases with decrease in temperature.

Display may turn black or dark Blue at temperature above its operational range; this is however not destructive and the display will return to normal once the temperature falls back to range.

Mechanical disturbance during operation (such as pressing on the viewing area) may cause the segments to appear "fractured". They will recover once the display is turned off.

Condensation at terminals will cause malfunction and possible electrochemical reaction. Relative humidity of the environment should therefore be kept below 60%.

(6) SAFETY

Liquid crystal may leak out of a damaged LCD, it is recommended to wash off the liquid crystal by using solvents such as acetone or ethanol and should be burned up later.

If any liquid leak out of a damaged glass cell comes in contact with your hands, wash it off with soap and water immediately.

WARRANTY

CLOVER will replace or repair any of her LCD module in accordance with her LCD specification for a period of one year from date of shipment. The warranty liability of Clover is limited to repair and/or replacement. Clover will not be responsible for any subsequent or consequential event.