

DIY Kit189. 120 Second Voice Recorder Module

This kit is the replacement for K64, our previous 120 second voice recorder module. This kit used the now obsolete ISD25120 chip. K189 uses the ISD17120 chip. It has much the same specifications as the previous chip but with some extra features that make it easier to use.

The ISD1700 series of chips offer a wide range of message durations, ranging from 30 seconds up to 240 seconds depending on the chip. The sampling frequency of each chip can also be adjusted from 4 kHz to 12 kHz with an external resistor, giving greater flexibility in duration versus recording quality.

Recordings are stored in on-chip Flash memory, providing non-volatile storage when power is removed. The audio data is stored directly without digital compression, which provides better quality voice and music reproduction.

These chips are designed for operation in either standalone or microcontroller (SPI) mode. This kit provides interfaces for both.

SPECIFICATIONS & FEATURES

Operating Voltage	8 to 24VDC (see text)
Sampling Frequency	8 kHz default (see text)
Message Length	120 seconds @ 8 kHz (see text)
Standalone Mode	Yes
SPI Mode interface	Yes
Input Source	Onboard electret microphone Analog Line In
Outputs	Direct drive to 8 ohm speaker Analog Aux Output
Visual Indicator	Onboard LED Stays ON during recording BLINKS during playback, etc.

KIT ASSEMBLY

Before starting, check the components supplied in the kit against the parts list.

NOTE: Some components are mounted inside the IC socket. Please ensure that these are pushed all the way into the PCB so they don't interfere with the IC when inserted into the socket.

NOTE: 5-pin header X3 is not required for standalone operation and has not been supplied.

It is recommended that components be inserted and soldered in the following order:

1. All the resistors and diode D2
2. All the 100nF mono capacitors.
3. The 28 pin IC socket
4. The LED and 78L05 regulator.
5. Slide switch S7
6. Electrolytic capacitors C3, C4 and C10 (4.7uF).
7. The electret microphone
8. Audio jacks X1 and X5
9. Screw terminal block X4

10. Pushbutton switches S1-6
11. DC jack X2
12. Electrolytic capacitor C11 (100uF)

Do not insert the IC into its socket yet. Connect a 9 to 12VDC supply to the kit and measure the voltage across pin 1 (+) and pin 28 (-). It should read 5 volts approx.

If OK then remove power and insert the IC. Take care not to bend any of the IC pins when doing so.

OPERATION

Operating control is via six (6) pushbuttons and one (1) slide switch, as follows:

- LINE/MIC** Slide switch to select recording source between external source (LINE) or onboard microphone (MIC)
- RECORD** Press and hold to start a new recording. LED is ON during recording. Release when done.
- PLAY** Plays the current message. Press and hold to play each message sequentially. LED blinks during playback.
- ERASE** Press to erase the current message. LED blinks twice then turns off when finished. Press and hold to erase ALL messages. LED blinks twice, stops then blinks another seven (7) times then turns off when finished.
- FWD** Advance to next message.
- VOL** Change playback volume in eight (8) steps.
- RESET** Return to the default state

NOTE: Each pushbutton has an associated pair of pads next to it. These are for connecting any externally mounted switches or pushbuttons. They simply connect across the onboard pushbuttons. Use either 2-pin headers or solder directly to the PCB.

CONNECTORS

- Power Supply** 2.5mm DC jack, center positive
- Line In** 3.5mm mono audio jack. Use for connecting to external audio source such as MP3 player or PC sound card. Slide switch must be set to 'LINE' position.
- Aux Output** 3.5mm mono audio jack. Use for connecting to external power amplifier.
- Speaker** 2-way screw terminal block

OPERATING VOLTAGE

The kit has an onboard 5V regulator, allowing it to run from an 8V to 24V DC power source. However the chip itself has an operating voltage range of 2.4V to 5.5V, making it suitable for battery powered applications.

To use these lower voltages the onboard 5V regulator can be omitted and a wire link soldered across the two (2) outer pins. Take care not to short to the centre pin. If the

DIY Kit189. 120 Second Voice Recorder Module

regulator is already soldered in then it can be left in place and the wire link added as above.

Diode D2 is used to provide protection against reverse polarity connection of the power supply. This diode will drop around 0.6 volts. It can also be omitted or 'shorted out' if necessary for battery operation.

SAMPLING FREQUENCY & MESSAGE LENGTH
The message length of the chip is dependent on the sampling frequency used. Reducing the sampling frequency will increase the message length but with reduced audio quality. This will not be a problem with many applications.

The sampling frequency is set by an external resistor, R4. The resistor supplied, 82K, sets the sampling frequency at 8 kHz which is the 'default' setting. Use the following chart to change the sampling frequency and hence the message length.

Sampling Frequency	Message Length	Resistor (R4) Value
12 kHz	80 secs	53 kΩ
8 kHz	120 secs	80 kΩ
6.4 kHz	150 secs	100 kΩ
5.3 kHz	181 secs	120 kΩ
4 kHz	240 secs	160 kΩ

SPI MODE

SPI mode allows full control of the chip via the serial interface. This includes random access to any location inside the memory array by specifying the start and end address. SPI mode also allows access to an internal register for configuration of audio paths, inputs, outputs and mixing.

The PCB allows for a 5-pin header, labeled X3, to be added so that a microcontroller can be used to control the chip. Please refer to the datasheet for further details. This header is not required for standalone operation and has not been supplied.

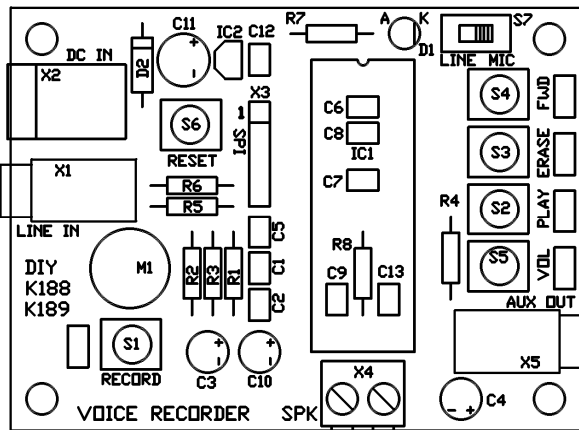

TROUBLESHOOTING

Most faults are due to assembly or soldering errors. Verify that you have the right components in the right place.

Inspect your work carefully under a bright light. The solder joints should have a 'shiny' look about them. Check that there are no solder bridges between adjacent pads.

Check that no IC pins are bent up under the body of the IC. This can sometimes happen when inserting ICs into sockets.

DATASHEET

A datasheet and for the ISD1700 series chips can be downloaded from the ISD website at

www.winbond-usa.com/products/isd_products/chipcorder

CONTACT DETAILS

For our full range of kits see our website at

<http://www.kitsrus.com>

Kit developer: <http://www.ozitronics.com>

PARTS LIST – K189

Resistors (0.25W carbon film unless specified)

390R.....	R8.....	1
470R.....	R5.....	1
1K.....	R6,7.....	2
4K7.....	R1,2,3.....	3
82K.....	R4.....	1

Capacitors

100nF mono, 0.1".....	C1,2,5,6,7,8,9,12,13.....	9
4.7uF 16V electrolytic.....	C3,4,10.....	3
100uF 25V electrolytic.....	C11.....	1

Semiconductors

LED, 3mm, red.....	D1.....	1
1N4004.....	D2.....	1
ISD17120 ChipCorder.....	IC1.....	1
78L05.....	IC2.....	1
5V regulator		

Miscellaneous

Electret microphone.....	M1.....	1
Pushbutton switch.....	S1,2,3,4,5,6.....	6
'Zippy' type, long stem		
Slide switch, SPDT.....	S7.....	1
DC jack, 2.5mm.....	X2.....	1
PCB mtg		
Audio jack, 3.5mm.....	X1,5.....	2
Mono, PCB mtg		
Screw terminal block.....	X4.....	1
2-way		
IC socket, 28 pin, for IC1.....		1
K188/K189 PCB.....		1

NOTE: 5-pin header X3 is not required for standalone operation and has not been supplied.

K189. 120 Second Voice Recorder Module

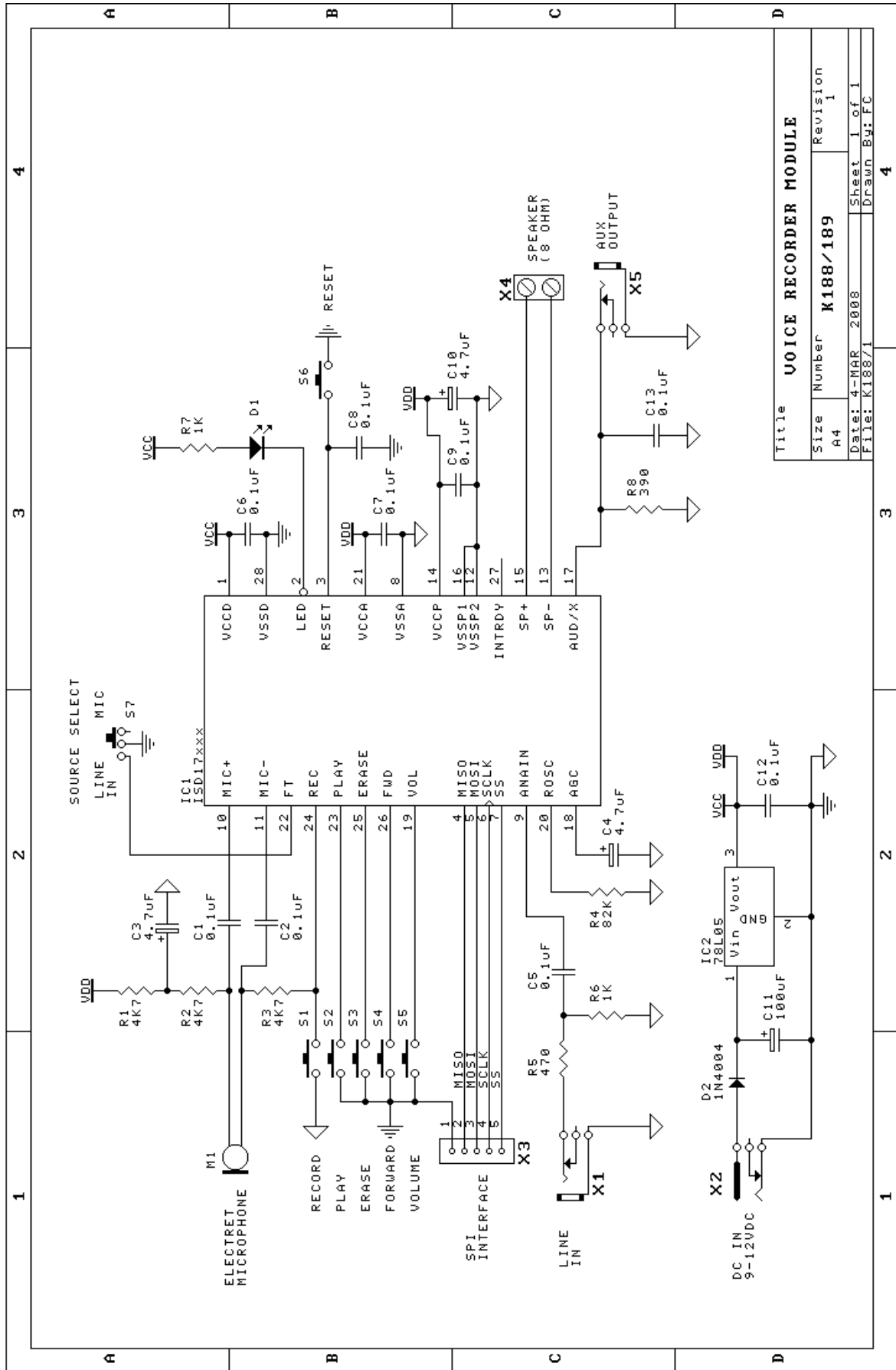

Title		
Size	Number	Revision
A4	K188/189	1
Date:	4-MAR-2008	Sheet 1 of 1
File:	K188/1	Drawn By: FC