

ERD SERIES

10x10 SIZE SEALED CONSTRUCTION ROTARY TYPE



ERD
1xxxx (Flat Type)



ERD
2xxxx (Shaft Type)



ERD
4XXXX (Flat Type)



ERD
5xxxx (Shaft Type)

FEATURES

- Molded-in terminals and fully sealed construction.
- Standard 2.54mm pin spacing.
- All plastics UL 94V-0 grade fire retardant.
- Reliable contact and long-term stability.
- Binary decimal (8 or 10 positions) and hexadecimal (16 positions), real and complementary codes available.
- Pin-out compatible with most of current equivalents.
- Gold plated contacts to ensure low contact resistance.

SPECIFICATIONS**1. ELECTRICAL**

Contact rating	
switching	25 mA, 24 VDC
non-switching	100 mA
Contact resistance	100 mΩ Max.
Insulation resistance	1000 MΩ Min. at 100 VDC
Dielectric strength	250 VAC Min. for 60 seconds

2. MECHANICAL

Temperature Rating	
operating	-25°C to +70°C
storage	-40°C to +85°C
Operation force	500 gf-cm Max.
Mechanical life	2000 steps per position
Vibration	10Hz-50Hz-10Hz for 6Hrs.
Solderability (for through hole type)	after flux 230±5°C for 5±0.5 seconds, 95% coverage
Resistance to soldering heat (for through hole type)	260±5°C for 5±1 seconds.

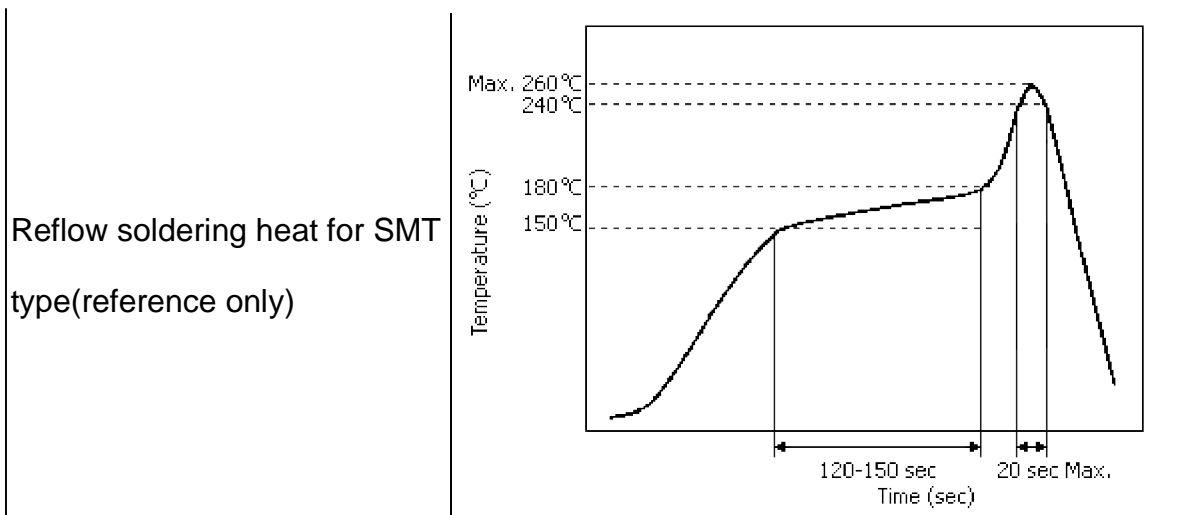

PART NUMBERING SYSTEM

```

ERD 1 10 R S X
|   |   |   |   |
|   |   |   |   | +--- Blank:Standard
|   |   |   |   |   Z:RoHS Compliant
|   |   |   |   | +--- Setting:
|   |   |   |   |   S:Standard Type (Top Adjust Type)
|   |   |   |   |   R:Right Angle Type with Rows Spacing
|   |   |   |   |     2.54mm Side Adjust Type)
|   |   |   |   |   F:Right Angle Type with Rows Spacing
|   |   |   |   |     5.08mm (Side Adjust Type)
|   |   |   |   |   M:Surface Mounting Type with
|   |   |   |   |     Top Tape Sealed
|   |   |   |   |   D:Surface Mounting Type with
|   |   |   |   |     Top Tape Sealed in Tape & Reel Package
|   |   |   |   | +--- Code: R:Real
|   |   |   |   |     C:Complement
|   |   |   |   | +--- Number of positions: 08,10,16
|   +--- Rotor: 1:Flat Type (pin out 3:3)
|               2:Shaft Type (pin out 3:3)
|               4:Flat Type (pin out 1:4)
|               5:Shaft Type (pin out 1:4)
+--- Series name: ERD:Rotary Type Sealed Construction
    
```

CODE

PIN NO.	POSITION															
	0	1	2	3	4	5	6	7	8	9	A	B	C	D	E	F
1	●	●	●	●	●	●	●	●	●	●	●	●	●	●	●	●
2	●	●	●	●	●	●	●	●	●	●	●	●	●	●	●	●
4	●	●	●	●	●	●	●	●	●	●	●	●	●	●	●	●
8	●	●	●	●	●	●	●	●	●	●	●	●	●	●	●	●

●Real Code
Rotor color: White (3:3), Yellow (1:4)

●Complement Code
Rotor color: Red (3:3), Orange (1:4)

CONSTRUCTION

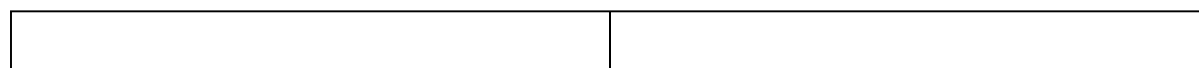

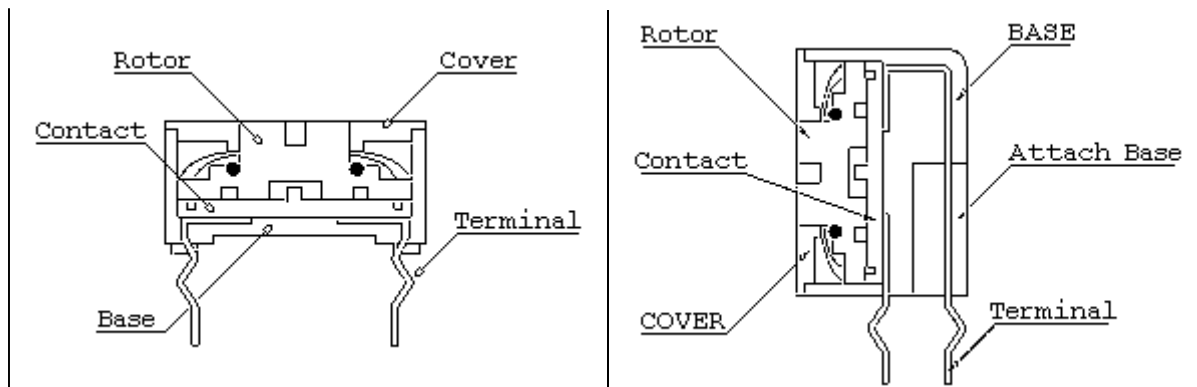

OPTIONS

- 1.Special marking available upon request.
- 2.Shaft Cover.
 - 418-80100(White 3:3)
 - 418-80200(Red 3:3)
 - 418-80300(Yellow 1:4)
 - 418-80400(Orange 1:4)

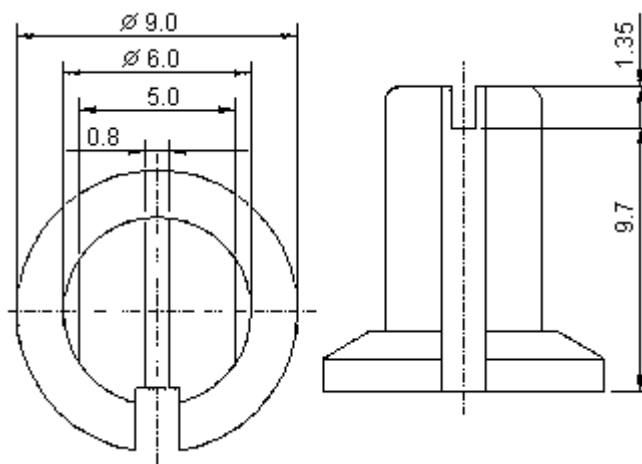

3.Tape & Reel Packaging (Per EIA STANDARD):

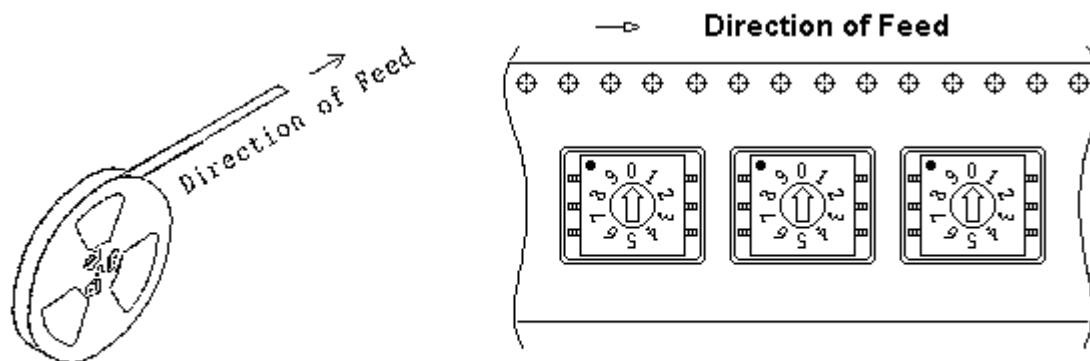

Each Reel contains 700pcs switches with a 390mm minimum leader and a 160mm minimum trailer

INTRODUCTION to ECE ROTARY DIP SWITCH

SIZE	POSITIONS	CODE	PIN OUT	ROTOR	TYPE	PART NUMBER
10x10	8,10,16	REAL, COMPLEMENT	3:3	FLAT, SHAFT	STANDARD	ERD1xxxS, ERD2xxxS
					RIGHT ANGLE	ERD1xxxR/F, ERD2xxxR/F
				FLAT	SMT	ERD1xxxM
			1:4		SMT IN T&R	ERD1xxxD
				FLAT, SHAFT	STANDARD	ERD4xxxS, ERD5xxxS
					RIGHT ANGLE	ERD4xxxR/F, ERD5xxxR/F
		FLAT	SMT	ERD4xxxM		

SMT IN T&R ERD4xxxD

DIMENSIONS AND CIRCUITRY UNIT:mm(inch) PIN OUT 3:3

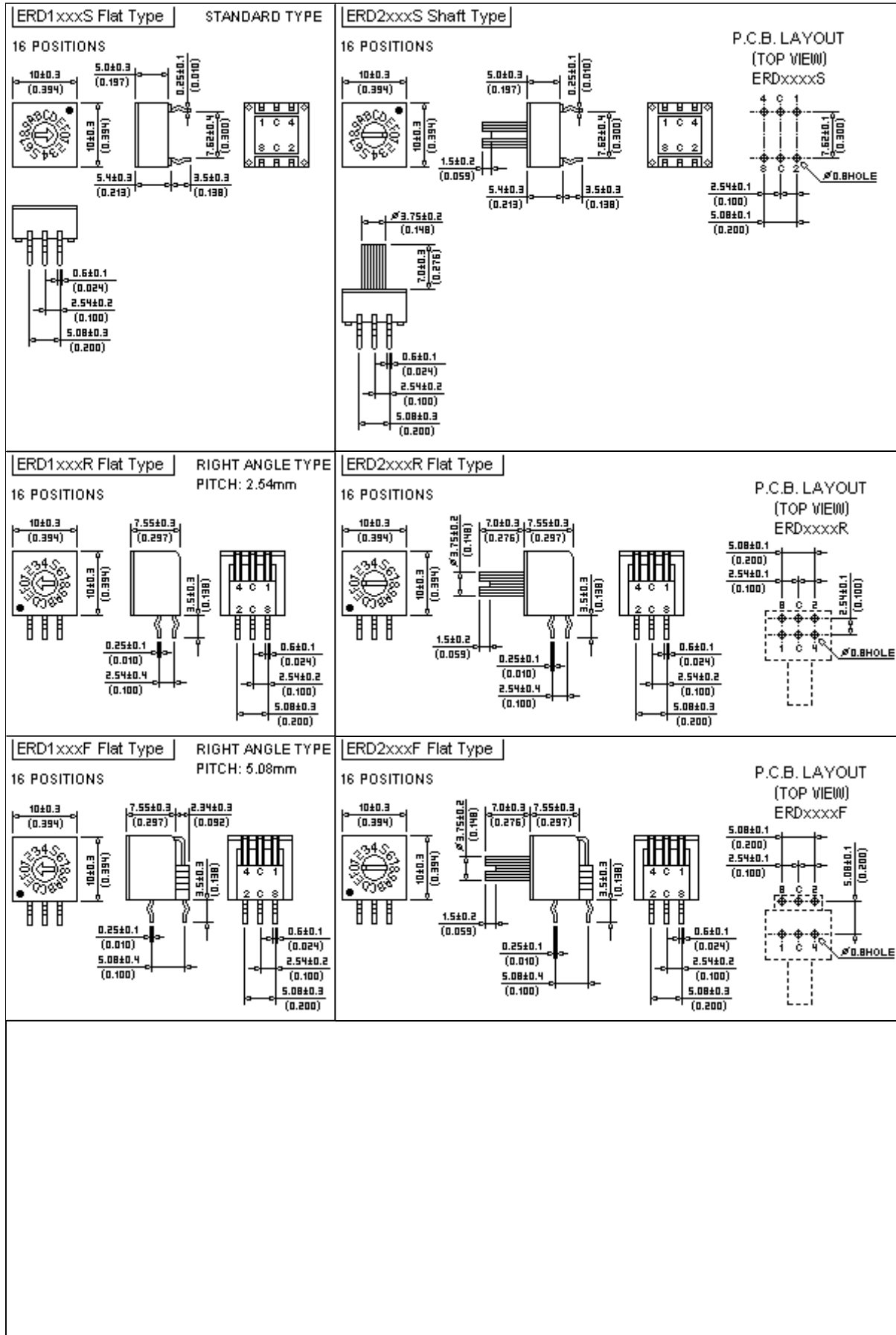

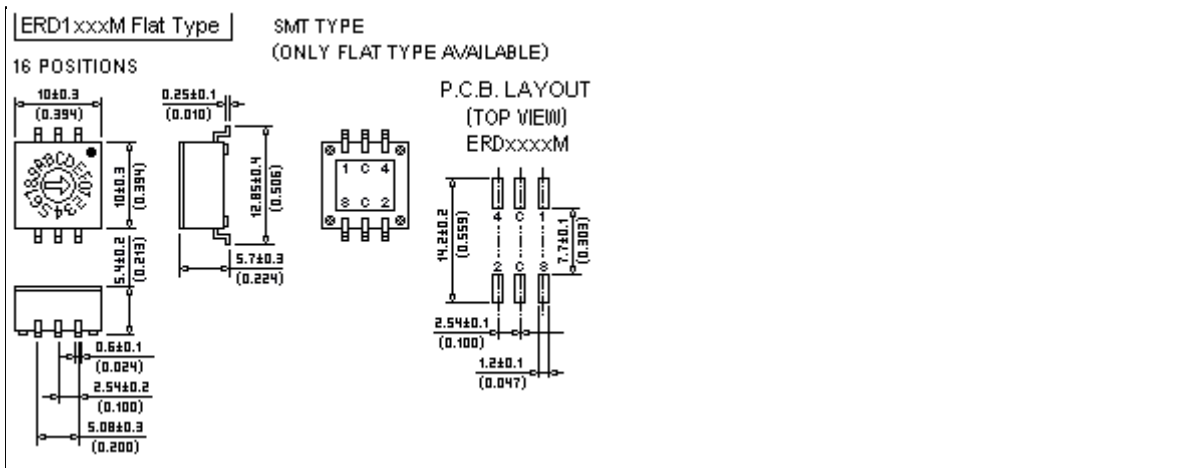

DIMENSIONS AND CIRCUITRY UNIT:mm(inch) PIN OUT 1:4

