

■

■ **SCOPE :**

This product specification specifies the product's performance and test methods as a basis for technical validation. The data parameters are for reference only. The parameters of different batches of products may change. The actual products received shall prevail. Please check with the manufacturer for accurate parameters.

■ **General Specification :**

2.1 Product application range:

- ◆ Backup power: RAM, detonator, car recorder, smart meter, vacuum switch, digital camera, motor drive
- ◆ Energy storage: intelligent three meters, UPS, security equipment, communication equipment, flashlights, water meters, gas meters, taillights, small appliances
- ◆ High current operation: electrified railway, smart grid control, hybrid vehicle, wireless transmission
- ◆ High power support: wind power generation, locomotive start, ignition, electric car, etc.

2.2 Standard test conditions:

The standard test conditions of this specification are standard atmospheric pressure, temperature 25 ° C, relative humidity less than 60%.

2.3 Test basis:

DL/T 1652-2016 "Technical Specifications for Supercapacitors for Electric Energy Metering Equipment"

■ Product Structure

The supercapacitor monomer product is based on the principle of an electric double layer capacitor. The inside uses activated carbon as a positive and negative electrode, and the electrolyte is separated from the diaphragm by an electrolyte, and the aluminum casing is sealed with a rubber stopper.

The supercapacitor module consists of multiple cells connected in series and parallel, and is equipped with a voltage equalization control management circuit.

KAMCAP

4 General Specification

Item		Specification/Condition
01	Part No	MK-16V-P10FYS 60F-6C1B-YS
02	Rate discharge capacitance (F 25°C ΔV=12V-6V I=1A)	10
03	Capacitance tolerance	-10%~+30%
04	Rated Voltage U0 (V)	16
05	Absolute Maximum Voltage (V)	16.2
06	Rated Current (A)	10
07	Maximum Peak Current, 1 second (non repetitive)	20
08	Balancing voltage type	Equipped with voltage equalization circuit
09	Operating temperature range	-40°C~65°C
10	Maximum equivalent series resistance ESR(mΩ 1KHz)	150
11	Shell packing	Thermoplastic casing
12	Output type	Lead pin output
13	Cycle life Expectancy	Add rated voltage, charge and discharge 500,000 times at room temperature. Δ C/C ≤30%, ESR ≤4 times the initial value(25°C)

5 Environmental

Item		Specification/Condition
01	Temperature characteristics	+70°C $\Delta C/C$ $\leq 30\%$, ESR \leq Specified value(25°C) -40°C $\Delta C/C$ $\leq 50\%$, ESR ≤ 4 times the specified value (25°C)
02	High temperature load	+70°C ± 2 Plus rated voltage, after 1000h, $\Delta C/C$ $\leq 30\%$, ESR ≤ 4 times the specified value.
03	High temperature without load	+70°C ± 2 , after 1000 ± 4 h, $\Delta C/C$ $\leq 30\%$, ESR ≤ 2 times the specified value.

6 KAM MARK

16V 10F

7 Product size

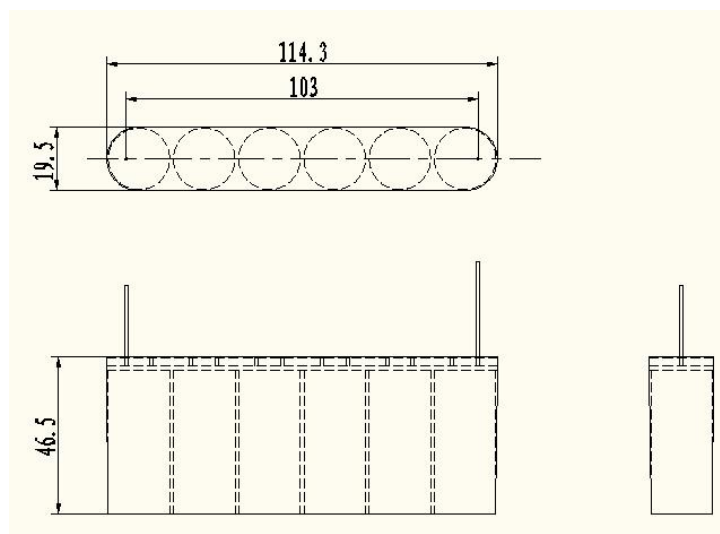

Size (mm ± 2 mm)	114.3 \times 19.5 \times 46.5
Down-lead distance(mm P) (± 1 mm)	103
Down-lead diameter(mm $\Phi d \pm 0.05$)	0.8
Down-lead Type	Positive: long lead pin Negative electrode: short lead pin

8 Precautions for use

- (1) Supercapacitors should be used at nominal voltage
- (2) The super capacitor has polarity and is used according to the specified polarity.
- (3) Ambient temperature affects the life of supercapacitors
- (4) There is a voltage drop $\Delta V=IR$ at the moment of discharge
- (5) It should be stored in an environment where the temperature is $-40^{\circ} \text{C} \sim 70^{\circ} \text{C}$ and the relative humidity is less than 60%.
- (6) Do not store in places with relative humidity greater than 85% or containing toxic gases
- (7) Supercapacitors should not be used in high frequency charging and discharging

circuits

(8) When supercapacitors are used in series, there is a voltage balance problem between cells

(9) For other problems, please consult the manufacturer or refer to the relevant technical information of the supercapacitor instructions.

(10) When some of our super capacitor modules are shipped from the factory, the positive and negative output terminals are short-circuited. Please disconnect the short-circuit positive and negative output wires before use or remove the short and positive output terminals of the product. route.

KAMCAP