

TO-126 (SOT-32) Plastic Package

BD135, BD137, BD139

BD135, 137, 139 NPN PLASTIC POWER TRANSISTORS
Complementary BD136, 138, 140
Medium Power Linear and Switching Applications

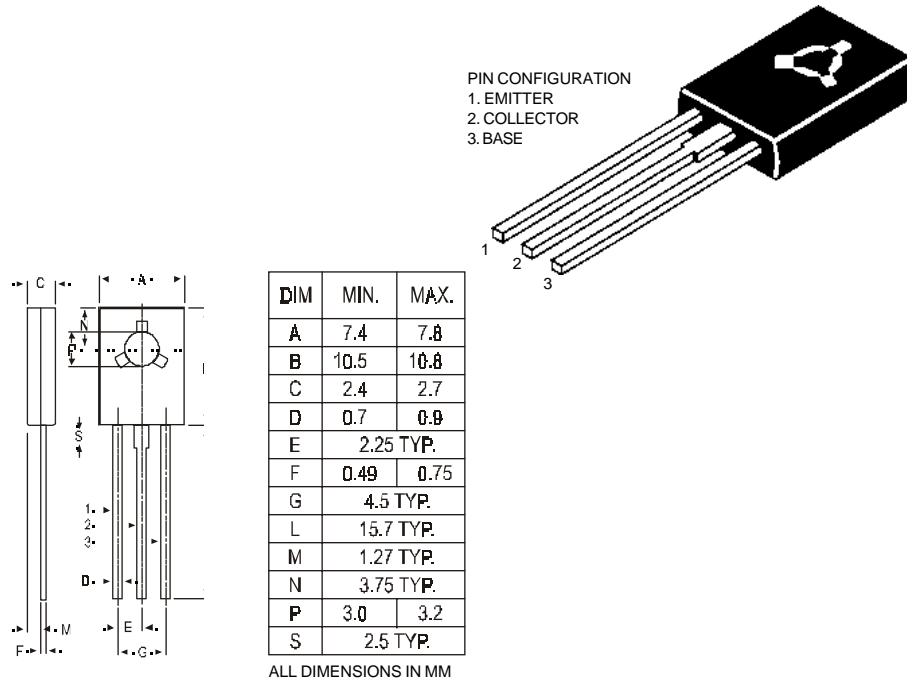

ABSOLUTE MAXIMUM RATINGS

		135	137	139	
Collector-base voltage (open emitter)	V_{CBO}	max. 45	60	100	V
Collector-emitter voltage (open base)	V_{CEO}	max. 45	60	80	V
Collector current	I_C	max.	1.5		A
Total power dissipation up to $T_C = 25^\circ C$	P_{tot}	max.	12.5		W
Junction temperature	T_j	max.	150		$^\circ C$
Collector-emitter saturation voltage $I_C = 0.5 A; I_B = 0.05 A$	V_{CEsat}	max.	0.5		V
D.C. current gain $I_C = 0.15 A; V_{CE} = 2 V$	h_{FE}	min.	40		
		max.	250		

RATINGS (at $T_A=25^\circ C$ unless otherwise specified)

Limiting values		135	137	139	
Collector-base voltage (open emitter)	V_{CBO}	max. 45	60	100	V
Collector-emitter voltage (open base)	V_{CEO}	max. 45	60	80	V
Emitter-base voltage (open collector)	V_{EBO}	max.	5.0		V

BD135, BD137, BD139

Collector current	I_C	max.	1.5	A
Base current	I_B	max.	0.5	A
Total power dissipation up to $T_A = 25^\circ\text{C}$	P_{tot}	max.	1.25	W
Derate above 25°C		max	10	mW/°C
Total power dissipation up to $T_C = 25^\circ\text{C}$	P_{tot}	max.	12.5	W
Derate above 25°C		max	100	mW/°C
Junction temperature	T_j	max.	150	°C
Storage temperature	T_{stg}		-65 to +150	°C

THERMAL RESISTANCE

From junction to case	R_{thj-c}		10	°C/W
From junction to ambient	R_{thj-a}		100	°C/W

CHARACTERISTICS

$T_{amb} = 25^\circ\text{C}$ unless otherwise specified

			135	137	139	
Collector cutoff current						
$I_E = 0; V_{CB} = 30\text{ V}$	I_{CBO}	max.	0.1			μA
$I_E = 0; V_{CB} = 30\text{ V}; T_C = 125^\circ\text{C}$	I_{CBO}	max.	10			μA
Emitter cut-off current						
$I_C = 0; V_{EB} = 5\text{ V}$	I_{EBO}	max.	10			μA
Breakdown voltages						
$I_C = 0.03\text{ A}; I_B = 0$	$V_{CEO(sus)}^*$	min.	45	60	80	V
$I_C = 1\text{ mA}; I_E = 0$	V_{CBO}	min.	45	60	100	V
$I_E = 1\text{ mA}; I_C = 0$	V_{EBO}	min.	5.0			V
Saturation voltage						
$I_C = 0.5\text{ A}; I_B = 0.05\text{ A}$	V_{CEsat}^*	max.	0.5			V
Base-emitter on voltage						
$I_C = 0.5\text{ A}; V_{CE} = 2\text{ V}$	$V_{BE(on)}^*$	max.	1.0			V
D.C. current gain						
$I_C = 0.005\text{ A}; V_{CE} = 2\text{ V}^*$	h_{FE}^*	min.	25			
$I_C = 0.15\text{ A}; V_{CE} = 2\text{ V}^{**}$	h_{FE}^*	min.	40			
		max.	250			
$I_C = 0.5\text{ A}; V_{CE} = 2\text{ V}^*$	h_{FE}^*	min.	25			
** h_{FE} classification:	-6	min.	40			
		max.	100			
	-10	min.	63			
		max.	160			
	-16	min.	100			
		max.	250			
	-25	min.	160			
		max.	400			

* Pulse test: pulse width $\leq 300\ \mu\text{s}$, duty cycle $\leq 2\%$.

