

# BRIGHT LED ELECTRONICS CORP.

## LED LAMPS SPECIFICATION

●COMMODITY : T-1 Standard 0.5"Lead , 3  $\phi$

●DEVICE NUMBER : BL-B2121

VERSION : 1.1 / 1998,07,14

●ELECTRICAL AND OPTICAL CHARACTERISTICS (Ta=25°C)

| Chip             |   | Lens<br>Appearance | Absolute Maximun<br>Rating |            |            |                | Electro-optical<br>Data (At 20mA) |      |                  | Viewing<br>Angle<br>2 $\theta$ 1/2<br>(deg) |
|------------------|---|--------------------|----------------------------|------------|------------|----------------|-----------------------------------|------|------------------|---|
| Emitted<br>Color | Peak<br>Wave<br>Length<br>$\lambda$ P(nm) |                    | $\Delta \lambda$<br>(nm)   | Pd<br>(mW) | If<br>(mA) | Peak<br>If(mA) | Vf(V)                             |      | Iv Typ.<br>(mcd) |   |
|                  |   |                    |                            |            |            |                | Typ.                              | Max. |                  |   |
| Green            | 568                                       | Green Diffused     | 30                         | 100        | 30         | 150            | 2.2                               | 2.6  | 20.0             | 50  |

Remark : Viewing angle is the Off-axis angle at which the luminous intensity is half the axial luminous intensity.

●ABSOLUTE MAXIMUN RATINGS (Ta=25°C)

|                                   |                     |
|-----------------------------------|---------------------|
| Reverse Voltage .....             | 5V                  |
| Reverse Current (-Vr=5V) .....    | 100 $\mu$ A         |
| Operating Temperature Range ..... | -40°C ~ 85°C        |
| Storage Temperature Range .....   | -40°C ~ 100°C       |
| Lead Soldering Temperature .....  | 260°C For 5 Seconds |

●PACKAGE DIMENSIONS

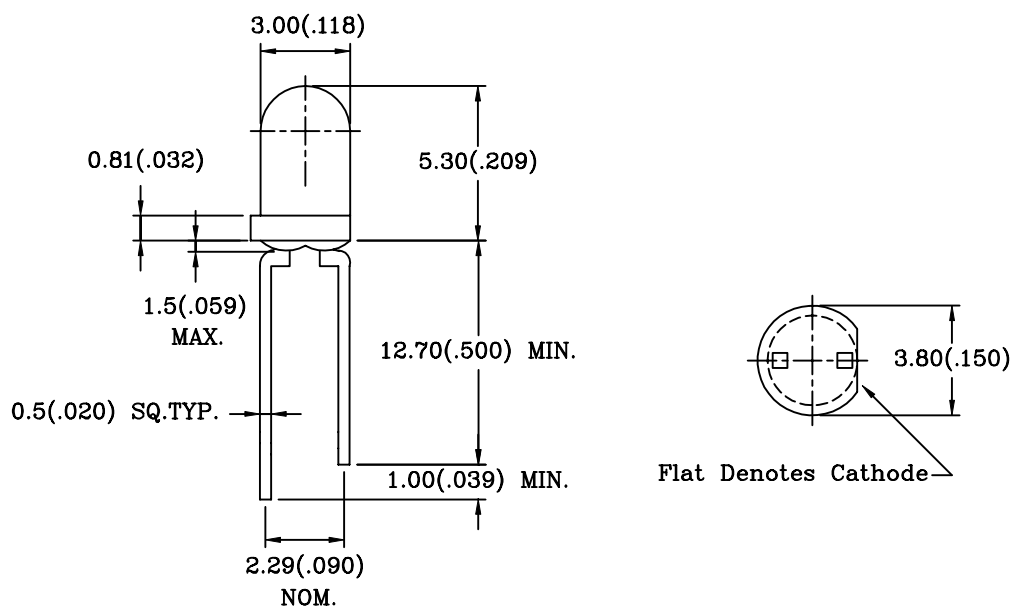

NOTES: 1.All dimensions are in millimeters (inches).

2.Tolerance is  $\pm 0.25$ mm (0.01") unless otherwise specified.

3.Lead spacing is measured where the leads emerge from the package.

4.Specifications are subject to change without notice.



# BRIGHT LED ELECTRONICS CORP.

## TYPICAL CHARACTERISTICS

DEVICE NUMBER: BL-B2121

### SPECTRAL DISTRIBUTION

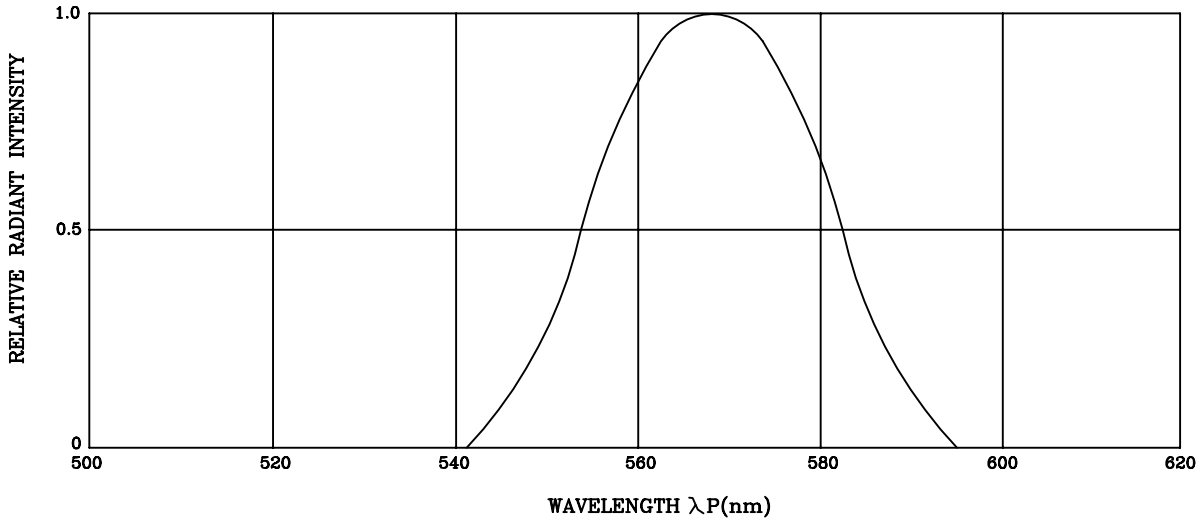

### FORWARD CURRENT VS. FORWARD VOLTAGE

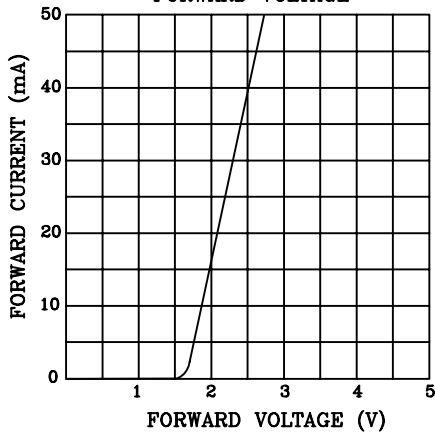

### RELATIVE LUMINOUS INTENSITY VS. AMBIENT TEMPERATURE

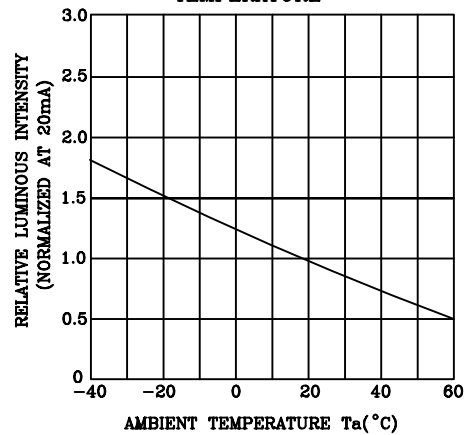

### RELATIVE LUMINOUS INTENSITY VS. FORWARD CURRENT

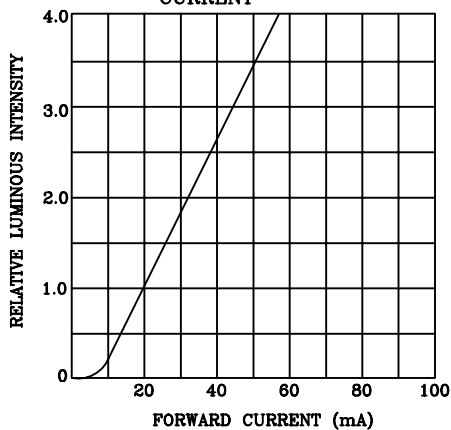

### RADIATION DIAGRAM

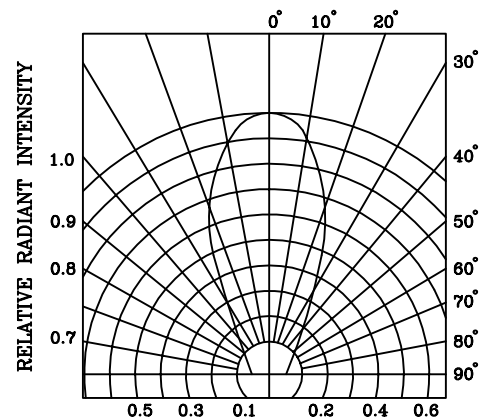

# RELIABILITY TEST

DEVICE NO.: BL-B2121

| Classification     | Test Item                                    | Reference Standard  | Test Conditions  | Result |
|--------------------|--|---|--|--------|
| Endurance Test     | Operation Life                               | MIL-STD-750:1026<br>MIL-STD-883:1005<br>JIS C 7021 :B-1                     | Connect with a power $I_f=30\text{mA}$<br>$T_a$ =Under room temperature<br>Test time=1,000hrs  | 0/100  |
|                    | High Temperature<br>High Humidity<br>Storage | MIL-STD-202:103B<br>JIS C 7021 :B-11  | $T_a=85^\circ\text{C}\pm 5^\circ\text{C}$<br>RH=90%-95%<br>Test time=1,000hrs  | 0/100  |
|                    | High Temperature<br>Storage                  | MIL-STD-883:1008<br>JIS C 7021 :B-10  | High $T_a=105^\circ\text{C}\pm 5^\circ\text{C}$<br>Test time=1,000hrs  | 0/100  |
|                    | Low Temperature<br>Storage                   | JIS-C-7021 :B-12  | Low $T_a=-55^\circ\text{C}\pm 5^\circ\text{C}$<br>Test time=1,000hrs   | 0/100  |
| Environmental Test | Temperature Cycling                          | MIL-STD-202:107D<br>MIL-STD-750:1051<br>MIL-STD-883:1010<br>JIS C 7021 :A-4 | $-55^\circ\text{C} \sim 25^\circ\text{C} \sim 105^\circ\text{C} \sim 25^\circ\text{C}$<br>30min 5min 30min 5min<br>Test Time=10cycle | 0/100  |
|                    | Thermal Shock                                | MIL-STD-202:107D<br>MIL-STD-750:1051<br>MIL-STD-883:1011                    | $105^\circ\text{C}\pm 5^\circ\text{C} \sim -55^\circ\text{C}\pm 5^\circ\text{C}$<br>10min 10min<br>Test Time=10cycle                 | 0/100  |
|                    | Solder Resistance                            | MIL-STD-202:201A<br>MIL-STD-750:2031<br>JIS C 7021 :A-1                     | $T_{\text{sol}}=260\pm 5^\circ\text{C}$<br>Dwell Time= $10\pm 1\text{sec.}$  | 0/50   |
|                    | Solderability                                | MIL-STD-202:208D<br>MIL-STD-750:2026<br>MIL-STD-883:2003<br>JIS C 7021 :A-2 | $T_{\text{sol}}=230\pm 5^\circ\text{C}$<br>Dwell Time= $5\pm 1\text{sec.}$   | 0/50   |
|                    | Lead Bending Stress                          | MIL-STD-750:2036<br>JIS C 7021 :A-11  | $0^\circ\sim 90^\circ\sim 0^\circ\text{bend}$ , 3 cycles<br>Weight 250g  | 0/50   |

## JUDGMENT CRITERIA OF FAILURE FOR THE RELIABILITY

| Measuring items    | Symbol | Measuring conditions | Judgement criteria for failure |
|--------------------|--------|----------------------|--------------------------------|
| Forward voltage    | VF     | $I_F=20\text{mA}$    | Over $U_x1.2$                  |
| Reverse current    | IR     | $V_R=5\text{V}$      | Over $U_x2$                    |
| Luminous intensity | IV     | $I_F=20\text{mA}$    | Below $S_x0.5$                 |

Note: 1.U means the upper limit of specified characteristics. S means initial value.

2.Measurment shall be taken between 2 hours and after the test pieces have been returned to normal ambient conditions after completion of each test.

