

REVISION RECORD

REV	ECN	DESCRIPTION	DRFT	DATE
-----	-----	-------------	------	------

NOTES1:

UL Standard

1. Rated voltage/current : 300V / 20A
2. Withstanding voltage : AC1600V/1Min.
3. Wire range : 24~12AWG

IEC Standard

1.	2	2	3
Pollution degree	III	III	II
Overvoltage category	4.0KV	4.0KV	4.0KV
Rate impulse voltage(KV)	630V	400V	250V
Rate voltage(V)	24A		
Rate current(A)			

2. Wire range : 0.2~4.0mm<sup>2</sup>(SOL)  
0.2~2.5mm<sup>2</sup>(STR)

NOTES2:

1. Dimension shall be interpreted per ASME Y14.5-2009
2. Pitch : 5.00mm, Poles : N=01~XXP
3. Stripping length : 10mm
4. Operating temperature : -40°C~+105°C
5. Undimensioned tolerances:

Pitch range in mm		Nominal dimension range in mm					-	∧	□
TO	Over TO	Over TO	TO	Over TO	Over TO	Over TO	0.1/10		
6	10	24	30	60	100	150	<		
±0.15	±0.20	±0.30	±0.30	±0.50	±0.70	±1.00	±1.30	±2*	

6. RoHS Compliance

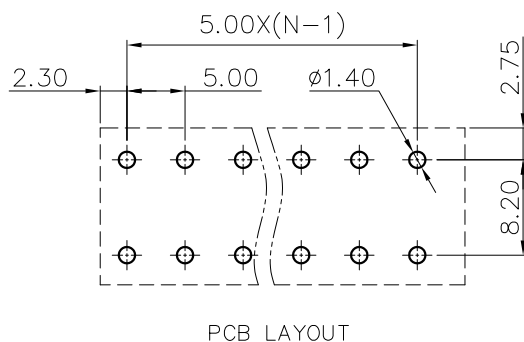
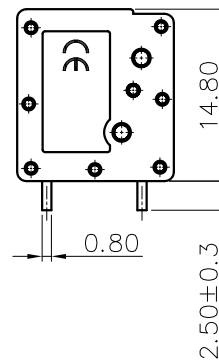
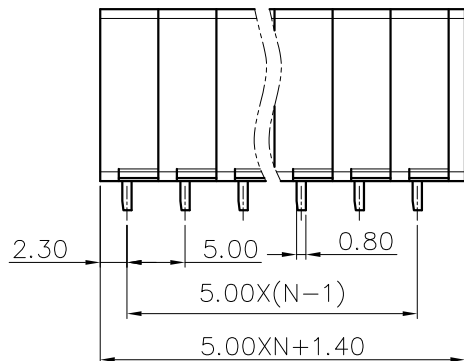
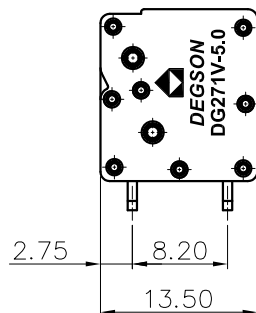
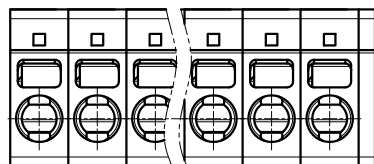
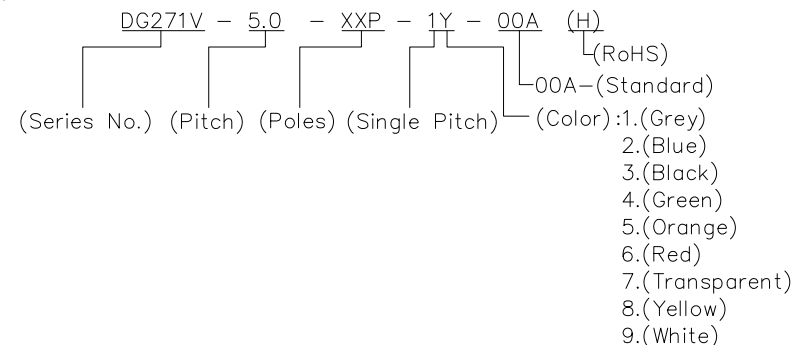

DETACHED LISTS	PART NO.:	NINGBO DEGSON ELECTRICAL CO., LTD			
	APPD:	NAME: DG271V-5.0-XXP-1Y-00A(H)			
	CHKD:	TITLE: CUSTOMER DRAWING		REV	D0
	DRFT:	DRAWING NO.:		SHEET	1/1
THIRD ANGLE PROJECTION		MM (INCH)	DO NOT SCALE DRAWING	SCALE	1:1