

LM2587 SIMPLE SWITCHER® 5A Flyback Regulator

Check for Samples: [LM2587](#)

FEATURES

- Requires Few External Components
- Family of Standard Inductors and Transformers
- NPN Output Switches 5.0A, can Stand Off 65V
- Wide Input Voltage Range: 4V to 40V
- Current-Mode Operation for Improved Transient Response, Line Regulation, and Current Limit
- 100 kHz Switching Frequency
- Internal Soft-Start Function Reduces In-Rush Current During Start-Up
- Output Transistor Protected by Current Limit, Under Voltage Lockout, and Thermal Shutdown
- System Output Voltage Tolerance of $\pm 4\%$ Max Over Line and Load Conditions

TYPICAL APPLICATIONS

- Flyback Regulator
- Multiple-Output Regulator
- Simple Boost Regulator
- Forward Converter

Flyback Regulator

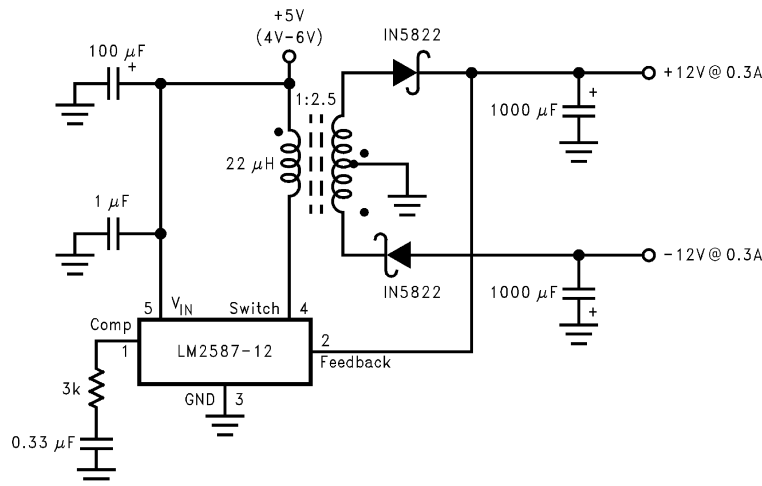
Figure 1.

DESCRIPTION

The LM2587 series of regulators are monolithic integrated circuits specifically designed for flyback, step-up (boost), and forward converter applications. The device is available in 4 different output voltage versions: 3.3V, 5.0V, 12V, and adjustable.

Requiring a minimum number of external components, these regulators are cost effective, and simple to use. Included in the datasheet are typical circuits of boost and flyback regulators. Also listed are selector guides for diodes and capacitors and a family of standard inductors and flyback transformers designed to work with these switching regulators.

The power switch is a 5.0A NPN device that can stand-off 65V. Protecting the power switch are current and thermal limiting circuits, and an undervoltage lockout circuit. This IC contains a 100 kHz fixed-frequency internal oscillator that permits the use of small magnetics. Other features include soft start mode to reduce in-rush current during start up, current mode control for improved rejection of input voltage and output load transients and cycle-by-cycle current limiting. An output voltage tolerance of $\pm 4\%$, within specified input voltages and output load conditions, is ensured for the power supply system.



Please be aware that an important notice concerning availability, standard warranty, and use in critical applications of Texas Instruments semiconductor products and disclaimers thereto appears at the end of this data sheet.

SIMPLE SWITCHER, Switchers Made Simple are registered trademarks of Texas Instruments. All other trademarks are the property of their respective owners.

Connection Diagrams

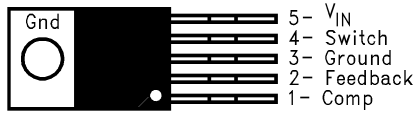

Figure 2. Bent, Staggered Leads 5-Lead TO-220 (NDH) Top View



Figure 3. Bent, Staggered Leads 5-Lead TO-220 (NDH) Side View

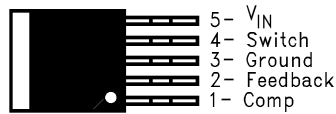
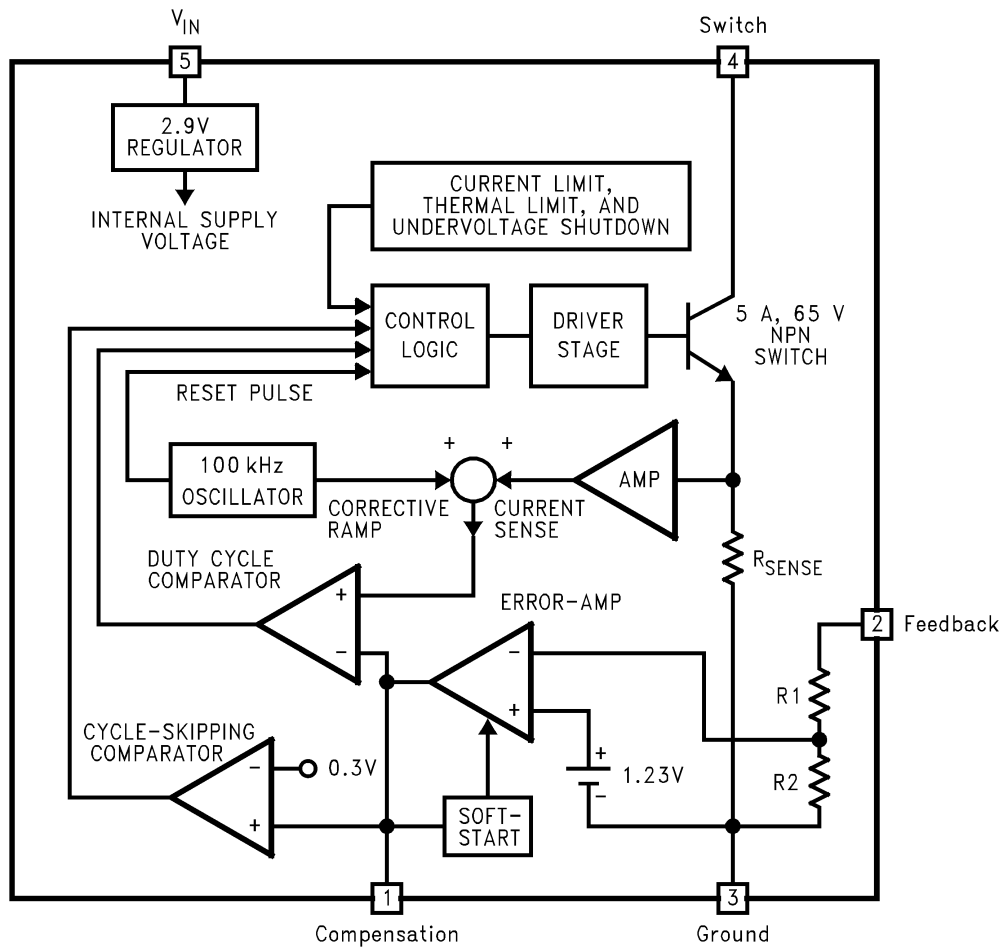

Figure 4. 5-Lead TO-263 (KTT) Top View



Figure 5. 5-Lead TO-263 (KTT) Side View



For Fixed Versions 3.3V, R1 = 3.4k, R2 = 2k5V, R1 = 6.15k, R2 = 2k12V, R1 = 8.73k, R2 = 1k For Adj. Version R1 = Short (0Ω), R2 = Open

Figure 6. Block Diagram

Test Circuits

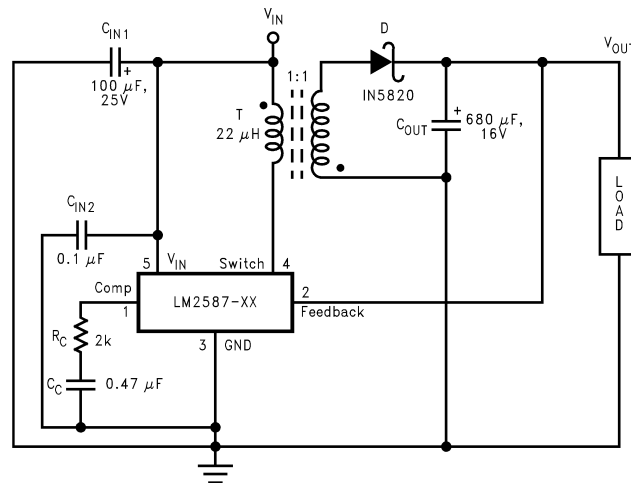

C_{IN1} —100 μ F, 25V Aluminum Electrolytic C_{IN2} —0.1 μ F Ceramic T—22 μ H, 1:1 Schott #67141450D—1N5820 C_{OUT} —680 μ F, 16V Aluminum Electrolytic C_C —0.47 μ F Ceramic R_C —2k

Figure 7. LM2587-3.3 and LM2587-5.0 Test Circuit

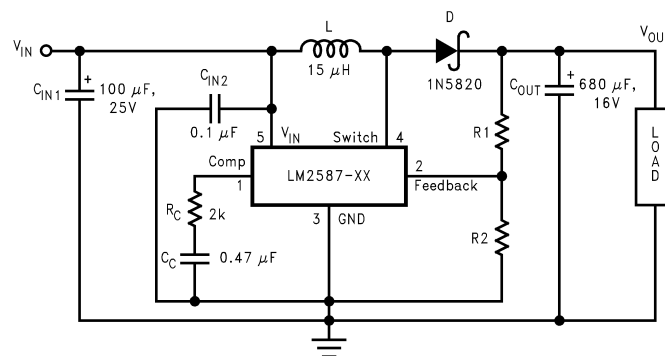

C_{IN1} —100 μ F, 25V Aluminum Electrolytic C_{IN2} —0.1 μ F Ceramic L—15 μ H, Renco #RL-5472-5D—1N5820 C_{OUT} —680 μ F, 16V Aluminum Electrolytic C_C —0.47 μ F Ceramic R_C —2k For 12V Devices: R_1 = Short (0 Ω) and R_2 = Open For ADJ Devices: R_1 = 48.75k, \pm 0.1% and R_2 = 5.62k, \pm 1%

Figure 8. LM2587-12 and LM2587-ADJ Test Circuit

Flyback Regulator Operation

The LM2587 is ideally suited for use in the flyback regulator topology. The flyback regulator can produce a single output voltage, such as the one shown in [Figure 9](#), or multiple output voltages. In [Figure 9](#), the flyback regulator generates an output voltage that is inside the range of the input voltage. This feature is unique to flyback regulators and cannot be duplicated with buck or boost regulators.

The operation of a flyback regulator is as follows (refer to [Figure 9](#)): when the switch is on, current flows through the primary winding of the transformer, T1, storing energy in the magnetic field of the transformer. Note that the primary and secondary windings are out of phase, so no current flows through the secondary when current flows through the primary. When the switch turns off, the magnetic field collapses, reversing the voltage polarity of the primary and secondary windings. Now rectifier D1 is forward biased and current flows through it, releasing the energy stored in the transformer. This produces voltage at the output.

The output voltage is controlled by modulating the peak switch current. This is done by feeding back a portion of the output voltage to the error amp, which amplifies the difference between the feedback voltage and a 1.230V reference. The error amp output voltage is compared to a ramp voltage proportional to the switch current (i.e., inductor current during the switch on time). The comparator terminates the switch on time when the two voltages are equal, thereby controlling the peak switch current to maintain a constant output voltage.

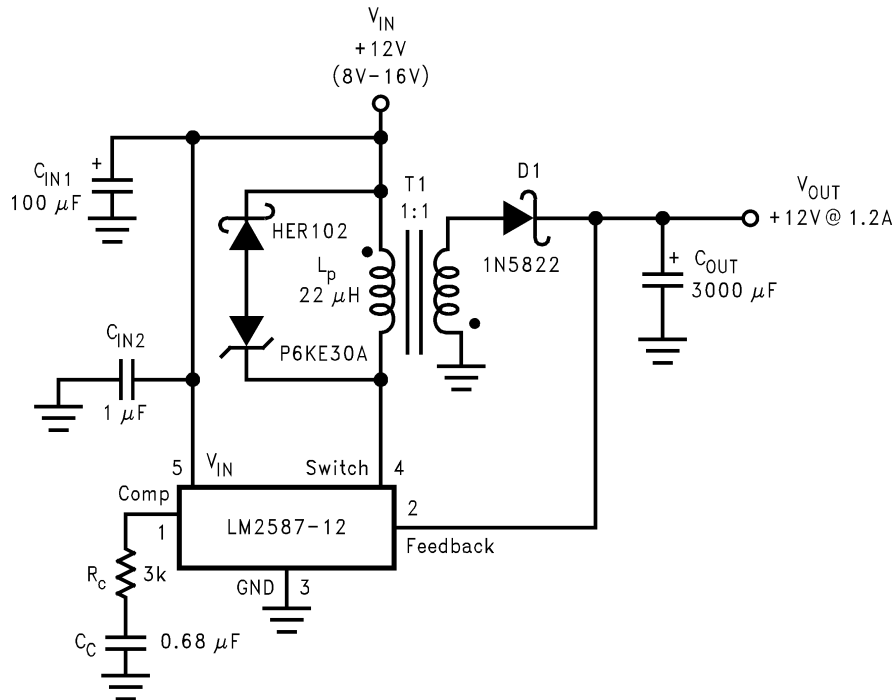

As shown in [Figure 9](#), the LM2587 can be used as a flyback regulator by using a minimum number of external components. The switching waveforms of this regulator are shown in [Figure 22](#). Typical Performance Characteristics observed during the operation of this circuit are shown in [Figure 23](#).

Figure 9. 12V Flyback Regulator Design Example



These devices have limited built-in ESD protection. The leads should be shorted together or the device placed in conductive foam during storage or handling to prevent electrostatic damage to the MOS gates.

Absolute Maximum Ratings⁽¹⁾⁽²⁾

Input Voltage		$-0.4V \leq V_{IN} \leq 45V$
Switch Voltage		$-0.4V \leq V_{SW} \leq 65V$
Switch Current ⁽³⁾		Internally Limited
Compensation Pin Voltage		$-0.4V \leq V_{COMP} \leq 2.4V$
Feedback Pin Voltage		$-0.4V \leq V_{FB} \leq 2 V_{OUT}$
Storage Temperature Range		$-65^{\circ}C$ to $+150^{\circ}C$
Lead Temperature	(Soldering, 10 sec.)	$260^{\circ}C$
Maximum Junction	Temperature ⁽⁴⁾	$150^{\circ}C$
Power Dissipation ⁽⁴⁾		Internally Limited
Minimum ESD Rating	(C = 100 pF, R = 1.5 k Ω)	2 kV

- (1) Absolute Maximum Ratings indicate limits beyond which damage to the device may occur. Operating ratings indicate conditions the device is intended to be functional, but device parameter specifications may not be ensured under these conditions. For ensured specifications and test conditions, see the Electrical Characteristics.
- (2) If Military/Aerospace specified devices are required, please contact the TI Sales Office/ Distributors for availability and specifications.
- (3) Note that switch current and output current are not identical in a step-up regulator. Output current cannot be internally limited when the LM2587 is used as a step-up regulator. To prevent damage to the switch, the output current must be externally limited to 5A. However, output current is internally limited when the LM2587 is used as a flyback regulator (see the [Application Hints](#) section for more information).
- (4) The junction temperature of the device (T_J) is a function of the ambient temperature (T_A), the junction-to-ambient thermal resistance (θ_{JA}), and the power dissipation of the device (P_D). A thermal shutdown will occur if the temperature exceeds the maximum junction temperature of the device: $P_D \times \theta_{JA} + T_{A(MAX)} \geq T_{J(MAX)}$. For a safe thermal design, check that the maximum power dissipated by the device is less than: $P_D \leq [T_{J(MAX)} - T_{A(MAX)}] / \theta_{JA}$. When calculating the maximum allowable power dissipation, derate the maximum junction temperature—this ensures a margin of safety in the thermal design.

Operating Ratings

Supply Voltage	$4V \leq V_{IN} \leq 40V$
Output Switch Voltage	$0V \leq V_{SW} \leq 60V$
Output Switch Current	$I_{SW} \leq 5.0A$
Junction Temperature Range	$-40^{\circ}C \leq T_J \leq +125^{\circ}C$

LM2587-3.3 Electrical Characteristics

Specifications with standard type face are for $T_J = 25^{\circ}C$, and those in **bold type face** apply over full **Operating Temperature Range**. Unless otherwise specified, $V_{IN} = 5V$.

Symbol	Parameters	Conditions	Typical	Min	Max	Units
SYSTEM PARAMETERS Test Circuit of Figure 7 ⁽¹⁾						
V_{OUT}	Output Voltage	$V_{IN} = 4V$ to $12V$ $I_{LOAD} = 400$ mA to $1.75A$	3.3	3.17/ 3.14	3.43/ 3.46	V
$\Delta V_{OUT} / \Delta V_{IN}$	Line Regulation	$V_{IN} = 4V$ to $12V$ $I_{LOAD} = 400$ mA	20		50/ 100	mV
$\Delta V_{OUT} / \Delta I_{LOAD}$	Load Regulation	$V_{IN} = 12V$ $I_{LOAD} = 400$ mA to $1.75A$	20		50/ 100	mV
η	Efficiency	$V_{IN} = 12V$, $I_{LOAD} = 1A$	75			%
UNIQUE DEVICE PARAMETERS ⁽²⁾						
V_{REF}	Output Reference Voltage	Measured at Feedback Pin $V_{COMP} = 1.0V$	3.3	3.242/ 3.234	3.358/ 3.366	V
ΔV_{REF}	Reference Voltage Line Regulation	$V_{IN} = 4V$ to $40V$	2.0			mV
G_M	Error Amp Transconductance	$I_{COMP} = -30$ μA to $+30$ μA $V_{COMP} = 1.0V$	1.193	0.678	2.259	mmho
A_{VOL}	Error Amp Voltage Gain	$V_{COMP} = 0.5V$ to $1.6V$ $R_{COMP} = 1.0$ M Ω ⁽³⁾	260	151/ 75		V/V

- (1) External components such as the diode, inductor, input and output capacitors can affect switching regulator performance. When the LM2587 is used as shown in [Figure 7](#) and [Figure 8](#), system performance will be as specified by the system parameters.
- (2) All room temperature limits are 100% production tested, and all limits at temperature extremes are specified via correlation using standard Statistical Quality Control (SQC) methods.
- (3) A 1.0 M Ω resistor is connected to the compensation pin (which is the error amplifier output) to ensure accuracy in measuring A_{VOL} .

LM2587-5.0 Electrical Characteristics

Specifications with standard type face are for $T_J = 25^\circ\text{C}$, and those in **bold type face** apply over full **Operating Temperature Range**. Unless otherwise specified, $V_{IN} = 5\text{V}$.

Symbol	Parameters	Conditions	Typical	Min	Max	Units
SYSTEM PARAMETERS Test Circuit of Figure 7 ⁽¹⁾						
V_{OUT}	Output Voltage	$V_{IN} = 4\text{V to }12\text{V}$ $I_{LOAD} = 500\text{ mA to }1.45\text{A}$	5.0	4.80/4.75	5.20/5.25	V
$\frac{\Delta V_{OUT}}{\Delta V_{IN}}$	Line Regulation	$V_{IN} = 4\text{V to }12\text{V}$ $I_{LOAD} = 500\text{ mA}$	20		50/100	mV
$\frac{\Delta V_{OUT}}{\Delta I_{LOAD}}$	Load Regulation	$V_{IN} = 12\text{V}$ $I_{LOAD} = 500\text{ mA to }1.45\text{A}$	20		50/100	mV
η	Efficiency	$V_{IN} = 12\text{V}$, $I_{LOAD} = 750\text{ mA}$	80			%
UNIQUE DEVICE PARAMETERS ⁽²⁾						
V_{REF}	Output Reference Voltage	Measured at Feedback Pin $V_{COMP} = 1.0\text{V}$	5.0	4.913/4.900	5.088/5.100	V
ΔV_{REF}	Reference Voltage Line Regulation	$V_{IN} = 4\text{V to }40\text{V}$	3.3			mV
G_M	Error Amp Transconductance	$I_{COMP} = -30\ \mu\text{A to }+30\ \mu\text{A}$ $V_{COMP} = 1.0\text{V}$	0.750	0.447	1.491	mmho
A_{VOL}	Error Amp Voltage Gain	$V_{COMP} = 0.5\text{V to }1.6\text{V}$ $R_{COMP} = 1.0\ \text{M}\Omega$ ⁽³⁾	165	99/49		V/V

- (1) External components such as the diode, inductor, input and output capacitors can affect switching regulator performance. When the LM2587 is used as shown in [Figure 7](#) and [Figure 8](#), system performance will be as specified by the system parameters.
- (2) All room temperature limits are 100% production tested, and all limits at temperature extremes are specified via correlation using standard Statistical Quality Control (SQC) methods.
- (3) A 1.0 M Ω resistor is connected to the compensation pin (which is the error amplifier output) to ensure accuracy in measuring A_{VOL} .

LM2587-12 Electrical Characteristics

Specifications with standard type face are for $T_J = 25^\circ\text{C}$, and those in **bold type face** apply over full **Operating Temperature Range**. Unless otherwise specified, $V_{IN} = 5\text{V}$.

Symbol	Parameters	Conditions	Typical	Min	Max	Units
SYSTEM PARAMETERS Test Circuit of Figure 8 ⁽¹⁾						
V_{OUT}	Output Voltage	$V_{IN} = 4\text{V to }10\text{V}$ $I_{LOAD} = 300\text{ mA to }1.2\text{A}$	12.0	11.52/11.40	12.48/12.60	V
$\frac{\Delta V_{OUT}}{\Delta V_{IN}}$	Line Regulation	$V_{IN} = 4\text{V to }10\text{V}$ $I_{LOAD} = 300\text{ mA}$	20		100/200	mV
$\frac{\Delta V_{OUT}}{\Delta I_{LOAD}}$	Load Regulation	$V_{IN} = 10\text{V}$ $I_{LOAD} = 300\text{ mA to }1.2\text{A}$	20		100/200	mV
η	Efficiency	$V_{IN} = 10\text{V}$, $I_{LOAD} = 1\text{A}$	90			%
UNIQUE DEVICE PARAMETERS ⁽²⁾						
V_{REF}	Output Reference Voltage	Measured at Feedback Pin $V_{COMP} = 1.0\text{V}$	12.0	11.79/11.76	12.21/12.24	V
ΔV_{REF}	Reference Voltage Line Regulation	$V_{IN} = 4\text{V to }40\text{V}$	7.8			mV
G_M	Error Amp Transconductance	$I_{COMP} = -30\ \mu\text{A to }+30\ \mu\text{A}$ $V_{COMP} = 1.0\text{V}$	0.328	0.186	0.621	mmho
A_{VOL}	Error Amp Voltage Gain	$V_{COMP} = 0.5\text{V to }1.6\text{V}$ $R_{COMP} = 1.0\ \text{M}\Omega$ ⁽³⁾	70	41/21		V/V

- (1) External components such as the diode, inductor, input and output capacitors can affect switching regulator performance. When the LM2587 is used as shown in [Figure 7](#) and [Figure 8](#), system performance will be as specified by the system parameters.
- (2) All room temperature limits are 100% production tested, and all limits at temperature extremes are specified via correlation using standard Statistical Quality Control (SQC) methods.
- (3) A 1.0 M Ω resistor is connected to the compensation pin (which is the error amplifier output) to ensure accuracy in measuring A_{VOL} .

LM2587-ADJ Electrical Characteristics

Specifications with standard type face are for $T_J = 25^\circ\text{C}$, and those in **bold type face** apply over full **Operating Temperature Range**. Unless otherwise specified, $V_{IN} = 5\text{V}$.

Symbol	Parameters	Conditions	Typical	Min	Max	Units
SYSTEM PARAMETERS Test Circuit of Figure 8 ⁽¹⁾						
V_{OUT}	Output Voltage	$V_{IN} = 4\text{V to }10\text{V}$ $I_{LOAD} = 300\text{ mA to }1.2\text{A}$	12.0	11.52/ 11.40	12.48/ 12.60	V
$\frac{\Delta V_{OUT}}{\Delta V_{IN}}$	Line Regulation	$V_{IN} = 4\text{V to }10\text{V}$ $I_{LOAD} = 300\text{ mA}$	20		100/ 200	mV
$\frac{\Delta V_{OUT}}{\Delta I_{LOAD}}$	Load Regulation	$V_{IN} = 10\text{V}$ $I_{LOAD} = 300\text{ mA to }1.2\text{A}$	20		100/ 200	mV
η	Efficiency	$V_{IN} = 10\text{V}$, $I_{LOAD} = 1\text{A}$	90			%
UNIQUE DEVICE PARAMETERS ⁽²⁾						
V_{REF}	Output Reference Voltage	Measured at Feedback Pin $V_{COMP} = 1.0\text{V}$	1.230	1.208/ 1.205	1.252/ 1.255	V
ΔV_{REF}	Reference Voltage Line Regulation	$V_{IN} = 4\text{V to }40\text{V}$	1.5			mV
G_M	Error Amp Transconductance	$I_{COMP} = -30\ \mu\text{A to }+30\ \mu\text{A}$ $V_{COMP} = 1.0\text{V}$	3.200	1.800	6.000	mmho
A_{VOL}	Error Amp Voltage Gain	$V_{COMP} = 0.5\text{V to }1.6\text{V}$ $R_{COMP} = 1.0\ \text{M}\Omega$ ⁽³⁾	670	400/ 200		V/V
I_B	Error Amp Input Bias Current	$V_{COMP} = 1.0\text{V}$	125		425/ 600	nA

(1) External components such as the diode, inductor, input and output capacitors can affect switching regulator performance. When the LM2587 is used as shown in [Figure 7](#) and [Figure 8](#), system performance will be as specified by the system parameters.

(2) All room temperature limits are 100% production tested, and all limits at temperature extremes are specified via correlation using standard Statistical Quality Control (SQC) methods.

(3) A 1.0 M Ω resistor is connected to the compensation pin (which is the error amplifier output) to ensure accuracy in measuring A_{VOL} .

All Output Voltage Versions Electrical Characteristics⁽¹⁾

Specifications with standard type face are for $T_J = 25^\circ\text{C}$, and those in **bold type face** apply over full **Operating Temperature Range**. Unless otherwise specified, $V_{IN} = 5\text{V}$.

Symbol	Parameters	Conditions	Typical	Min	Max	Units
I_S	Input Supply Current	(Switch Off) See ⁽²⁾	11		15.5/ 16.5	mA
		$I_{SWITCH} = 3.0\text{A}$	85		140/ 165	mA
V_{UV}	Input Supply Undervoltage Lockout	$R_{LOAD} = 100\ \Omega$	3.30	3.05	3.75	V
f_O	Oscillator Frequency	Measured at Switch Pin $R_{LOAD} = 100\ \Omega$ $V_{COMP} = 1.0\text{V}$	100	85/ 75	115/ 125	kHz
f_{SC}	Short-Circuit Frequency	Measured at Switch Pin $R_{LOAD} = 100\ \Omega$ $V_{FEEDBACK} = 1.15\text{V}$	25			kHz
V_{EAO}	Error Amplifier Output Swing	Upper Limit See ⁽³⁾	2.8	2.6/ 2.4		V
		Lower Limit See ⁽²⁾	0.25		0.40/ 0.55	V
I_{EAO}	Error Amp Output Current (Source or Sink)	See ⁽⁴⁾	165	110/ 70	260/ 320	μA

(1) All room temperature limits are 100% production tested, and all limits at temperature extremes are specified via correlation using standard Statistical Quality Control (SQC) methods.

(2) To measure this parameter, the feedback voltage is set to a high value, depending on the output version of the device, to force the error amplifier output low. Adj: $V_{FB} = 1.41\text{V}$; 3.3V: $V_{FB} = 3.80\text{V}$; 5.0V: $V_{FB} = 5.75\text{V}$; 12V: $V_{FB} = 13.80\text{V}$.

(3) To measure this parameter, the feedback voltage is set to a low value, depending on the output version of the device, to force the error amplifier output high. Adj: $V_{FB} = 1.05\text{V}$; 3.3V: $V_{FB} = 2.81\text{V}$; 5.0V: $V_{FB} = 4.25\text{V}$; 12V: $V_{FB} = 10.20\text{V}$.

(4) To measure the worst-case error amplifier output current, the LM2587 is tested with the feedback voltage set to its low value (specified in Note 7) and at its high value (specified in Note 8).

All Output Voltage Versions Electrical Characteristics⁽¹⁾ (continued)

Specifications with standard type face are for $T_J = 25^\circ\text{C}$, and those in **bold type face** apply over full **Operating Temperature Range**. Unless otherwise specified, $V_{IN} = 5\text{V}$.

Symbol	Parameters	Conditions	Typical	Min	Max	Units
I_{SS}	Soft Start Current	$V_{FEEDBACK} = 0.92\text{V}$ $V_{COMP} = 1.0\text{V}$	11.0	8.0/ 7.0	17.0/ 19.0	μA
D	Maximum Duty Cycle	$R_{LOAD} = 100\Omega$ See ⁽³⁾	98	93/ 90		%
I_L	Switch Leakage Current	Switch Off $V_{SWITCH} = 60\text{V}$	15		300/ 600	μA
V_{SUS}	Switch Sustaining Voltage	$dV/dT = 1.5\text{V/ns}$		65		V
V_{SAT}	Switch Saturation Voltage	$I_{SWITCH} = 5.0\text{A}$	0.7		1.1/ 1.4	V
I_{CL}	NPN Switch Current Limit		6.5	5.0	9.5	A
COMMON DEVICE PARAMETERS⁽⁵⁾						
θ_{JA}	Thermal Resistance	NDH Package, Junction to Ambient ⁽⁶⁾	65			$^\circ\text{C/W}$
θ_{JA}		NDH Package, Junction to Ambient ⁽⁷⁾	45			
θ_{JC}		NDH Package, Junction to Case	2			
θ_{JA}		KTT Package, Junction to Ambient ⁽⁸⁾	56			
θ_{JA}		KTT Package, Junction to Ambient ⁽⁹⁾	35			
θ_{JA}		KTT Package, Junction to Ambient ⁽¹⁰⁾	26			
θ_{JC}	KTT Package, Junction to Case	2				

- (5) External components such as the diode, inductor, input and output capacitors can affect switching regulator performance. When the LM2587 is used as shown in [Figure 7](#) and [Figure 8](#), system performance will be as specified by the system parameters.
- (6) Junction to ambient thermal resistance (no external heat sink) for the 5 lead TO-220 package mounted vertically, with ½ inch leads in a socket, or on a PC board with minimum copper area.
- (7) Junction to ambient thermal resistance (no external heat sink) for the 5 lead TO-220 package mounted vertically, with ½ inch leads soldered to a PC board containing approximately 4 square inches of (1oz.) copper area surrounding the leads.
- (8) Junction to ambient thermal resistance for the 5 lead TO-263 mounted horizontally against a PC board area of 0.136 square inches (the same size as the TO-263 package) of 1 oz. (0.0014 in. thick) copper.
- (9) Junction to ambient thermal resistance for the 5 lead TO-263 mounted horizontally against a PC board area of 0.4896 square inches (3.6 times the area of the TO-263 package) of 1 oz. (0.0014 in. thick) copper.
- (10) Junction to ambient thermal resistance for the 5 lead TO-263 mounted horizontally against a PC board copper area of 1.0064 square inches (7.4 times the area of the TO-263 package) of 1 oz. (0.0014 in. thick) copper. Additional copper area will reduce thermal resistance further. See the thermal model in Switchers Made Simple[®] software.

Typical Performance Characteristics

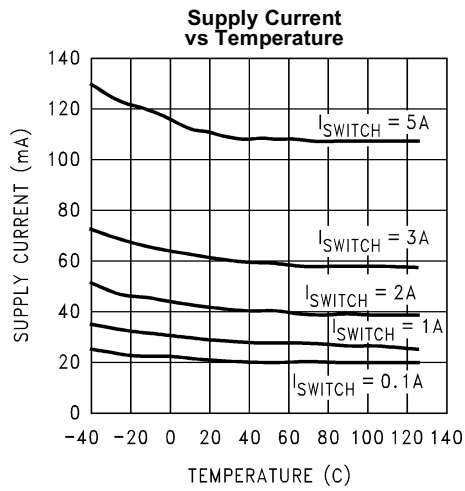

Figure 10.

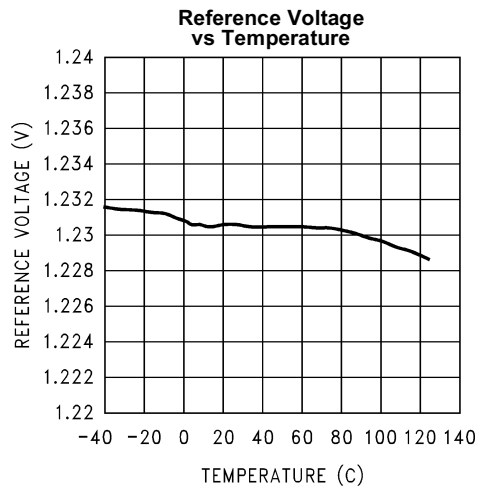

Figure 11.

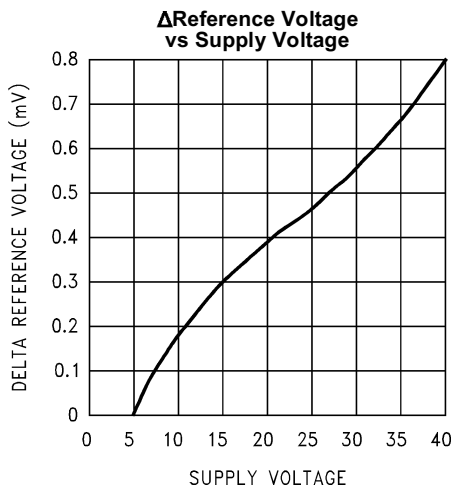

Figure 12.

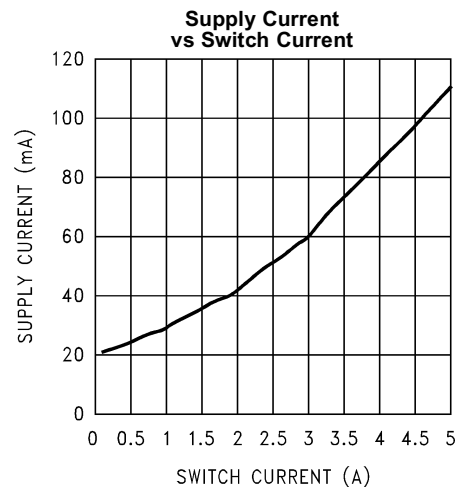

Figure 13.

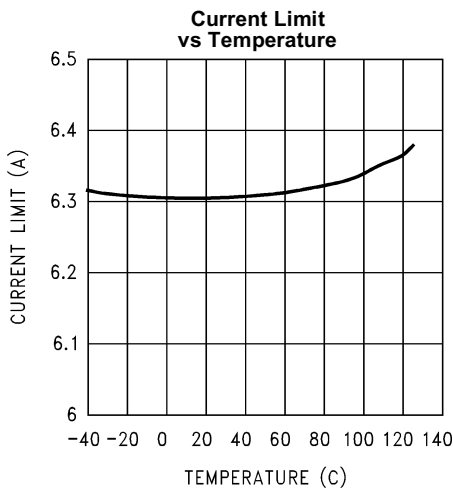

Figure 14.

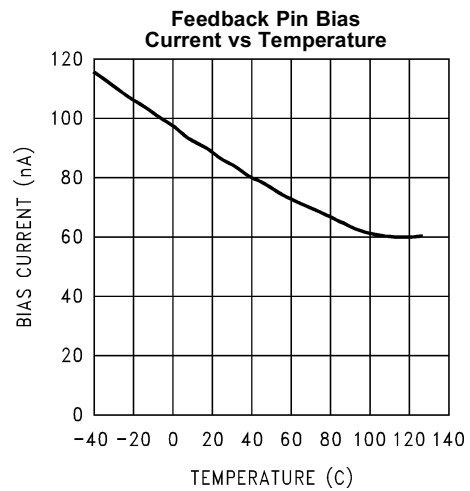

Figure 15.

Typical Performance Characteristics (continued)

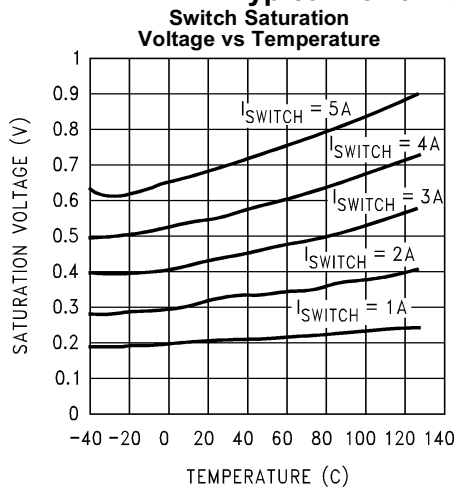

Figure 16.

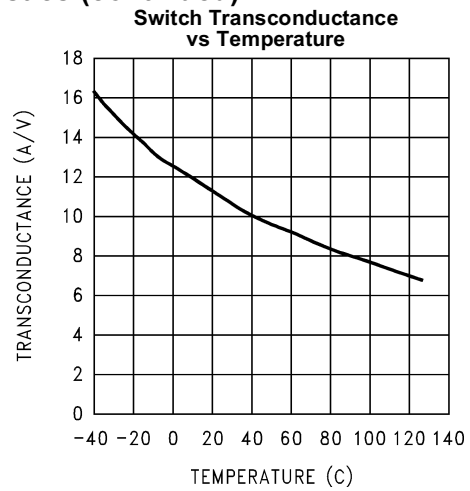

Figure 17.

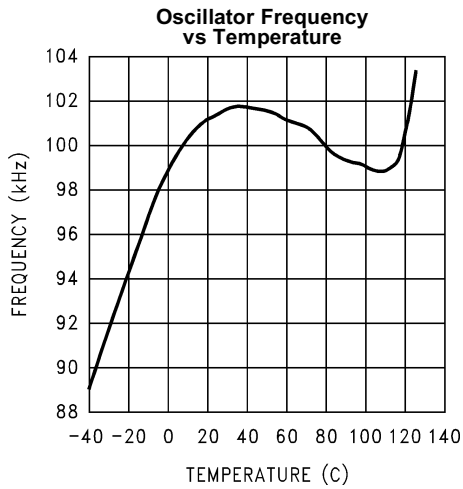

Figure 18.

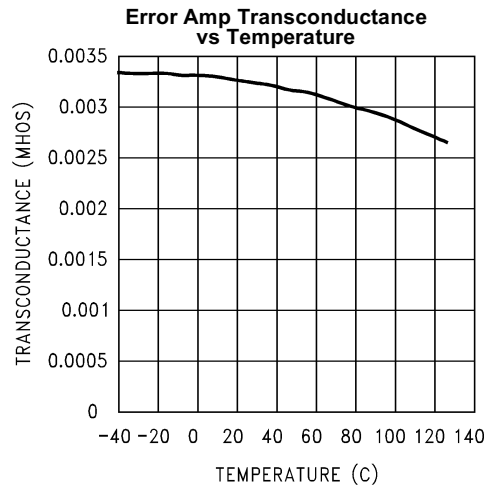

Figure 19.

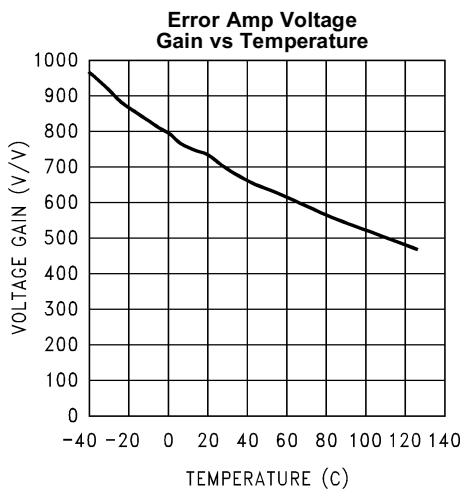

Figure 20.

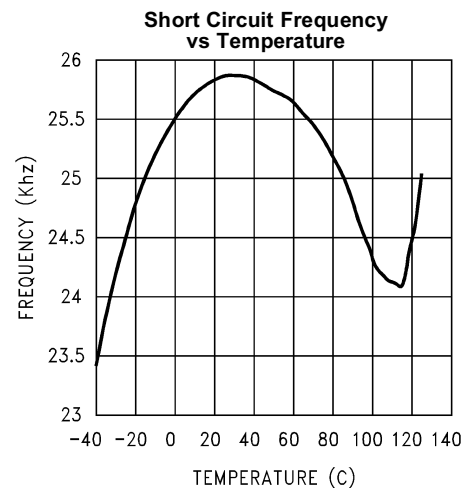
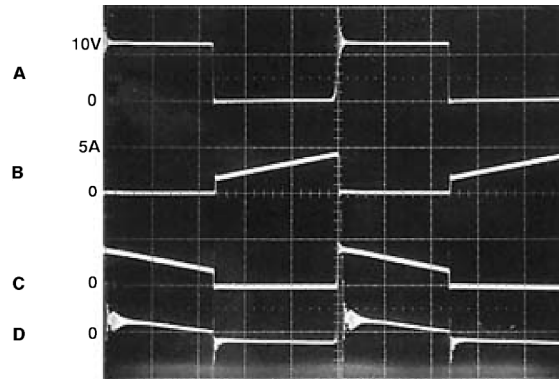

Figure 21.

Performance Characteristics



A: Switch Voltage, 10 V/div B: Switch Current, 5 A/div C: Output Rectifier Current, 5 A/div D: Output Ripple Voltage, 100 mV/div
AC-Coupled
Horizontal: 2 μ s/div

Figure 22. Switching Waveforms

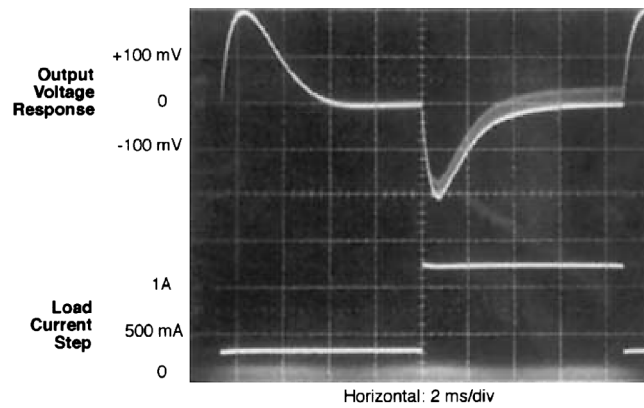

Figure 23. V_{OUT} Load Current Step Response

TYPICAL FLYBACK REGULATOR APPLICATIONS

Figure 24 Figure 25 Figure 26 Figure 27 Figure 28 show six typical flyback applications, varying from single output to triple output. Each drawing contains the part number(s) and manufacturer(s) for every component except the transformer. For the transformer part numbers and manufacturers names, see the table in [TRANSFORMER SELECTION \(T\)](#). For applications with different output voltages—requiring the LM2587-ADJ—or different output configurations that do not match the standard configurations, refer to the **Switchers Made Simple** software.

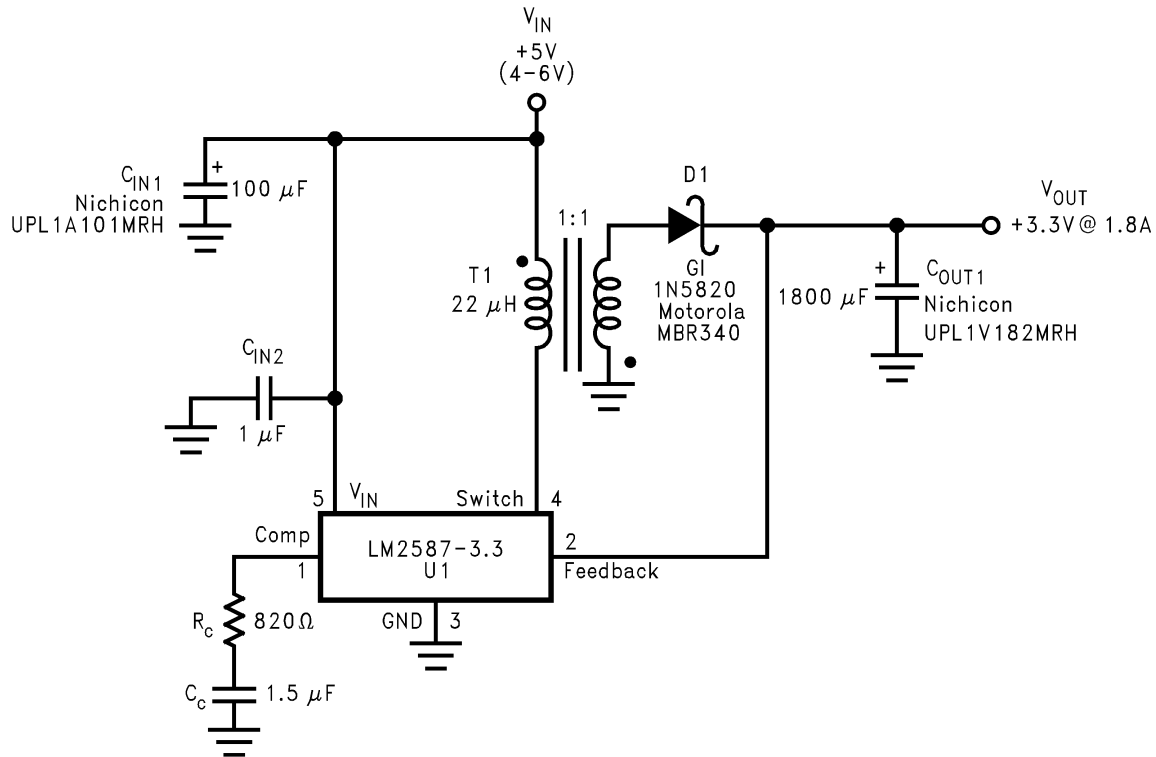

Figure 24. Single-Output Flyback Regulator

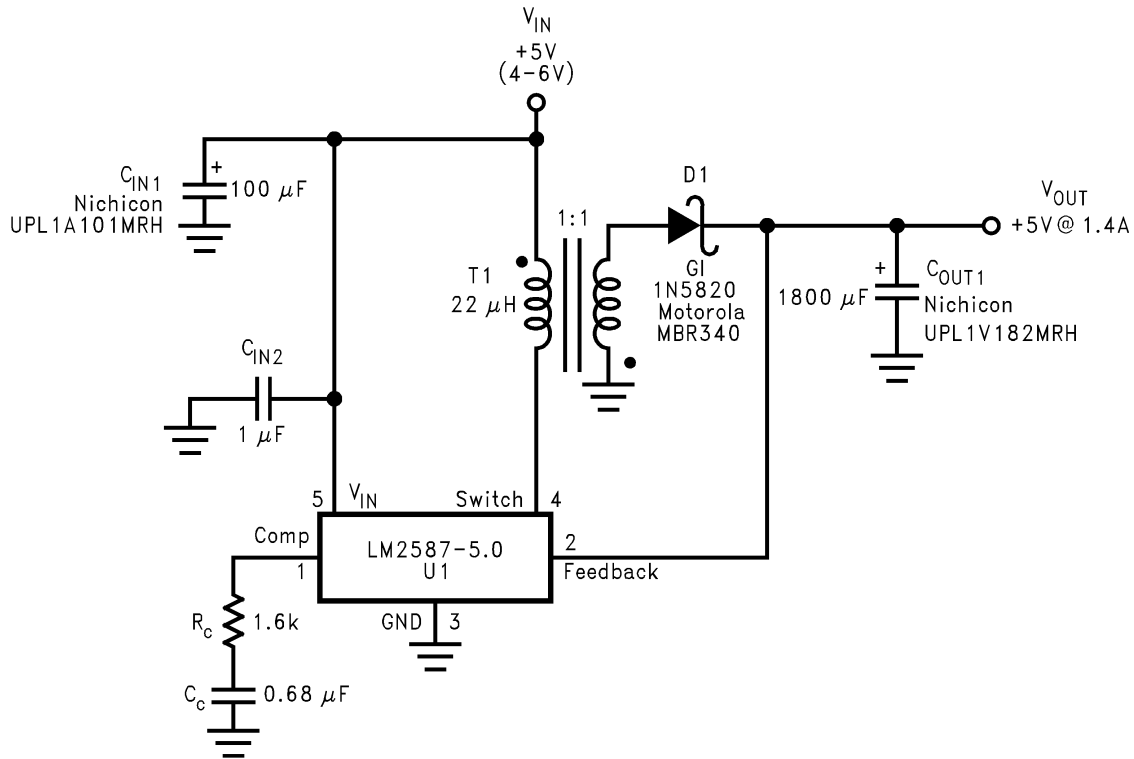

Figure 25. Single-Output Flyback Regulator

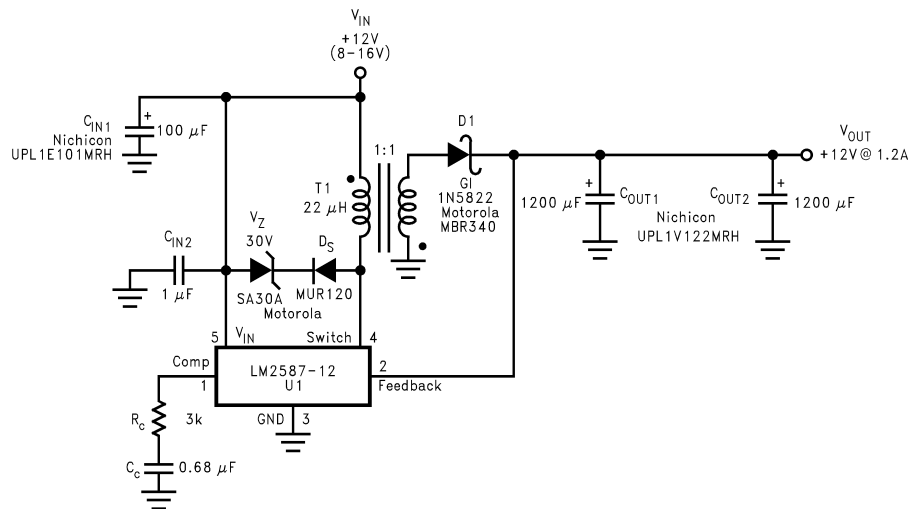

Figure 26. Single-Output Flyback Regulator

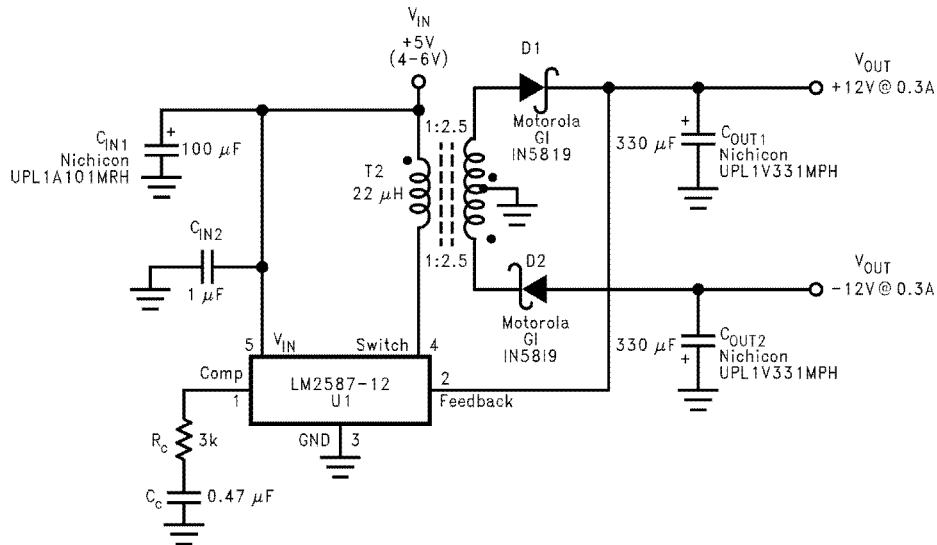

Figure 27. Dual-Output Flyback Regulator

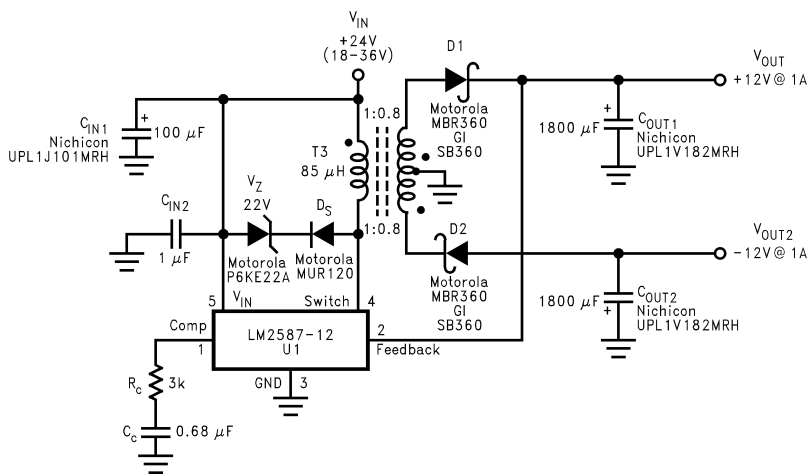

Figure 28. Dual-Output Flyback Regulator

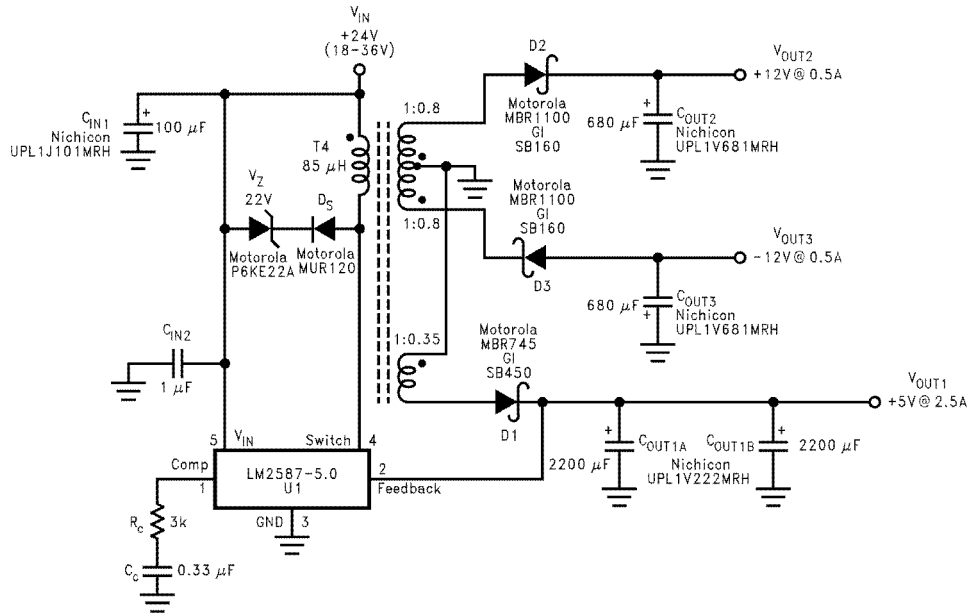

Figure 29. Triple-Output Flyback Regulator

TRANSFORMER SELECTION (T)

Table 1 lists the standard transformers available for flyback regulator applications. Included in the table are the turns ratio(s) for each transformer, as well as the output voltages, input voltage ranges, and the maximum load currents for each circuit.

Table 1. Transformer Selection Table

Applications	Figure 24	Figure 25	Figure 26	Figure 27	Figure 28	Figure 29
Transformers	T1	T1	T1	T2	T3	T4
V _{IN}	4V–6V	4V–6V	8V–16V	4V–6V	18V–36V	18V–36V
V _{OUT1}	3.3V	5V	12V	12V	12V	5V
I _{OUT1} (Max)	1.8A	1.4A	1.2A	0.3A	1A	2.5A
N ₁	1	1	1	2.5	0.8	0.35
V _{OUT2}				-12V	-12V	12V
I _{OUT2} (Max)				0.3A	1A	0.5A
N ₂				2.5	0.8	0.8
V _{OUT3}						-12V
I _{OUT3} (Max)						0.5A
N ₃						0.8

Table 2. Transformer Manufacturer Guide

Transformer Type	Manufacturers' Part Numbers				
	Coilcraft ⁽¹⁾	Coilcraft ⁽¹⁾ Surface Mount	Pulse ⁽²⁾ Surface Mount	Renco ⁽³⁾	Schott ⁽⁴⁾
T1	Q4434-B	Q4435-B	PE-68411	RL-5530	67141450
T2	Q4337-B	Q4436-B	PE-68412	RL-5531	67140860
T3	Q4343-B	—	PE-68421	RL-5534	67140920

(1) Coilcraft Inc., Phone: (800) 322-2645/1102 Silver Lake Road, Cary, IL 60013: Fax: (708) 639-1469
 (2) Pulse Engineering Inc., Phone: (619) 674-8100/12220 World Trade Drive, San Diego, CA 92128: Fax: (619) 674-8262
 (3) Renco Electronics Inc., Phone: (800) 645-5828/60 Jeffry Blvd. East, Deer Park, NY 11729: Fax: (516) 586-5562
 (4) Schott Corp., Phone: (612) 475-1173/1000 Parkers Lane Road, Wayzata, MN 55391: Fax: (612) 475-1786

Table 2. Transformer Manufacturer Guide (continued)

Transformer Type	Manufacturers' Part Numbers				
	Coilcraft ⁽¹⁾	Coilcraft ⁽¹⁾	Pulse ⁽²⁾	Renco ⁽³⁾	Schott ⁽⁴⁾
		Surface Mount	Surface Mount		
T4	Q4344-B	—	PE-68422	RL-5535	67140930

TRANSFORMER FOOTPRINTS

Figure 30, Figure 31, Figure 32, Figure 33, Figure 34, Figure 35, Figure 36, Figure 37, Figure 38, Figure 39, Figure 40, Figure 41, Figure 42, Figure 43, Figure 44, Figure 45, Figure 46, and Figure 47 show the footprints of each transformer, listed in Table 1.

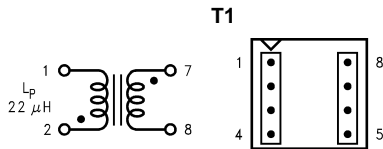

Figure 30. Coilcraft Q4434-B (Top View)

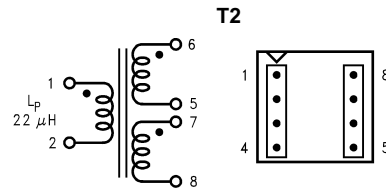

Figure 31. Coilcraft Q4337-B (Top View)

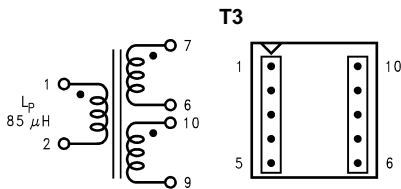

Figure 32. Coilcraft Q4343-B (Top View)

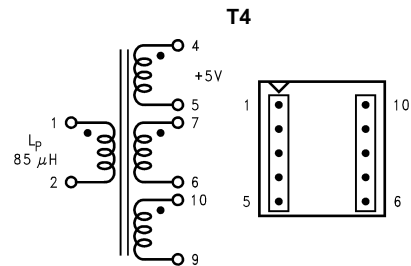

Figure 33. Coilcraft Q4344-B (Top View)

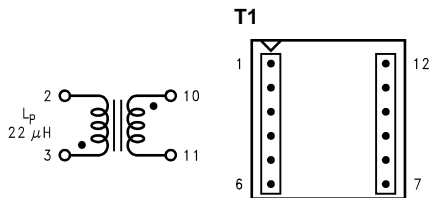

Figure 34. Coilcraft Q4435-B (Surface Mount) (Top View)

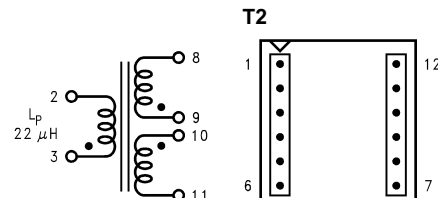

Figure 35. Coilcraft Q4436-B (Surface Mount) (Top View)

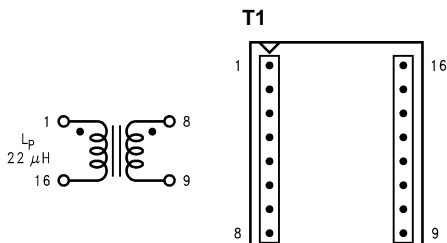

Figure 36. Pulse PE-68411 (Surface Mount) (Top View)

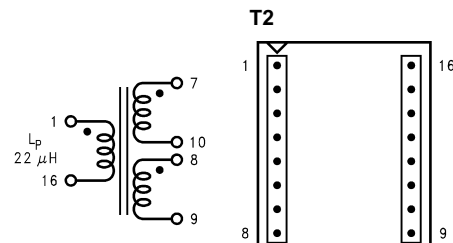

Figure 37. Pulse PE-68412 (Surface Mount) (Top View)

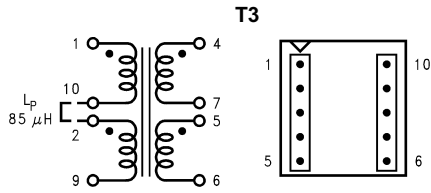

Figure 38. Pulse PE-68421 (Surface Mount) (Top View)

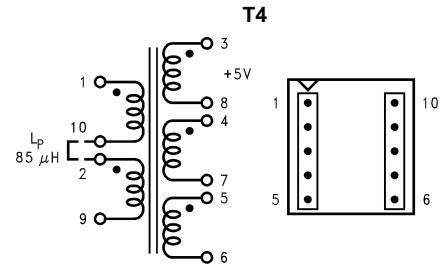

Figure 39. Pulse PE-68422 (Surface Mount) (Top View)

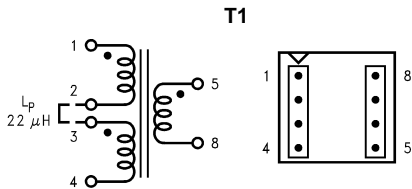

Figure 40. Renco RL-5530 (Top View)

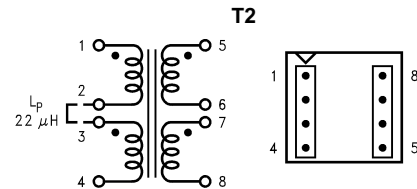

Figure 41. Renco RL-5531 (Top View)

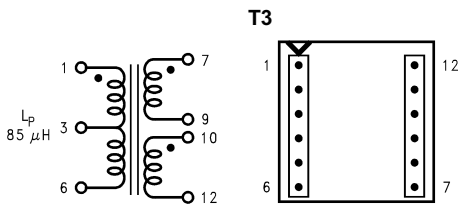

Figure 42. Renco RL-5534 (Top View)

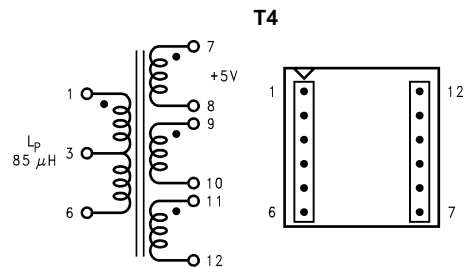

Figure 43. Renco RL-5535 (Top View)

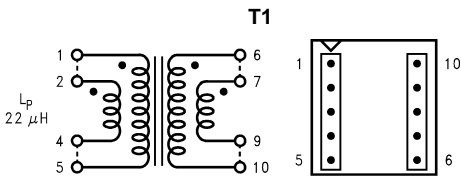

Figure 44. Schott 67141450 (Top View)

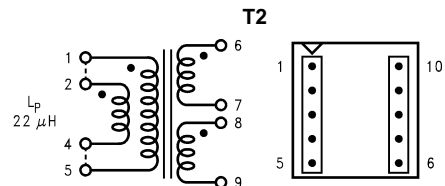

Figure 45. Schott 67140860 (Top View)

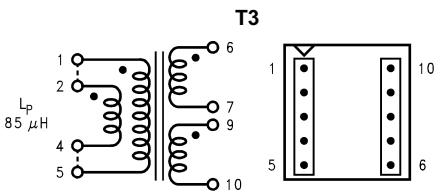

Figure 46. Schott 67140920 (Top View)

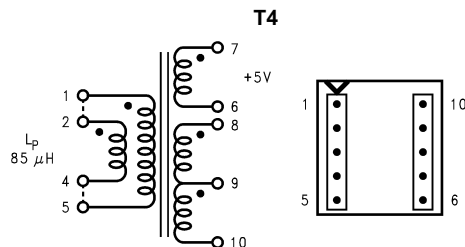
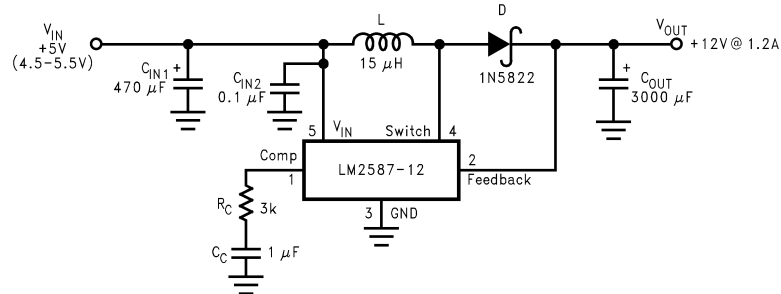

Figure 47. Schott 67140930 (Top View)

Step-Up (Boost) Regulator Operation

Figure 48 shows the LM2587 used as a step-up (boost) regulator. This is a switching regulator that produces an output voltage greater than the input supply voltage.

A brief explanation of how the LM2587 Boost Regulator works is as follows (refer to [Figure 48](#)). When the NPN switch turns on, the inductor current ramps up at the rate of V_{IN}/L , storing energy in the inductor. When the switch turns off, the lower end of the inductor flies above V_{IN} , discharging its current through diode (D) into the output capacitor (C_{OUT}) at a rate of $(V_{OUT} - V_{IN})/L$. Thus, energy stored in the inductor during the switch on time is transferred to the output during the flyback time. The output voltage is controlled by adjusting the peak switch current, as described in the [Flyback Regulator Operation](#) section.



By adding a small number of external components (as shown in [Figure 48](#)), the LM2587 can be used to produce a regulated output voltage that is greater than the applied input voltage. The switching waveforms observed during the operation of this circuit are shown in [Figure 49](#). Typical performance of this regulator is shown in [Figure 50](#).

Figure 48. 12V Boost Regulator

Typical Performance Characteristics

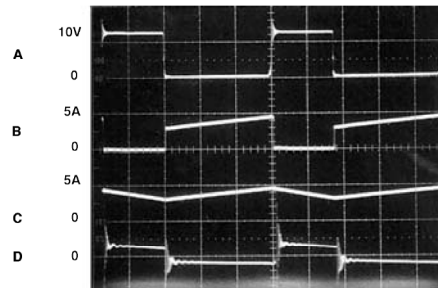

A: Switch Voltage, 10 V/div
B: Switch Current, 5 A/div
C: Inductor Current, 5 A/div
D: Output Ripple Voltage, 100 mV/div, AC-Coupled
Horizontal: 2 μs/div

Figure 49. Switching Waveforms

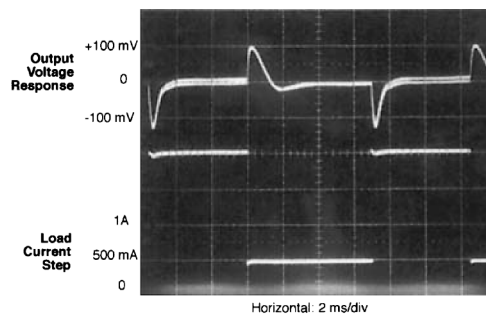

Figure 50. V_{OUT} Response to Load Current Step

Typical Boost Regulator Applications

[Figure 51](#) and [Figure 52](#) [Figure 53](#) and [Figure 54](#) show four typical boost applications)—one fixed and three using the adjustable version of the LM2587. Each drawing contains the part number(s) and manufacturer(s) for every component. For the fixed 12V output application, the part numbers and manufacturers' names for the inductor are listed in a table in [Figure 54](#). For applications with different output voltages, refer to the **Switchers Made Simple** software.

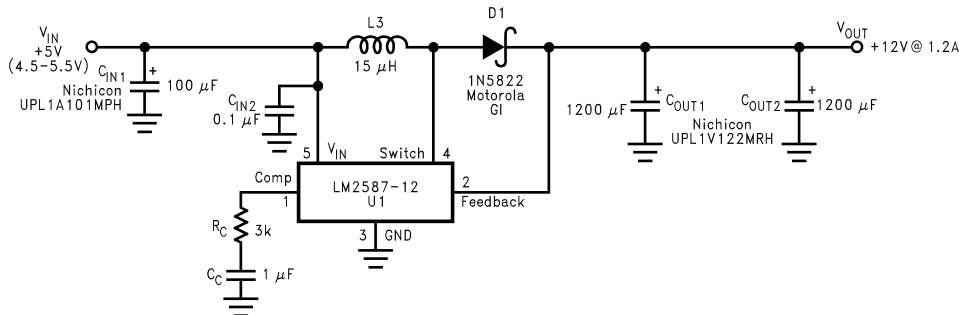

Figure 51. +5V to +12V Boost Regulator

Table 3 contains a table of standard inductors, by part number and corresponding manufacturer, for the fixed output regulator of Figure 51.

Table 3. Inductor Selection Table

Coilcraft (1)	Pulse (2)	Renco (3)	Schott (4)
R4793-A	PE-53900	RL-5472-5	67146520

- (1) Coilcraft Inc., Phone: (800) 322-2645/1102 Silver Lake Road, Cary, IL 60013: Fax: (708) 639-1469
- (2) Pulse Engineering Inc., Phone: (619) 674-8100/12220 World Trade Drive, San Diego, CA 92128: Fax: (619) 674-8262
- (3) Renco Electronics Inc., Phone: (800) 645-5828/60 Jeffryn Blvd. East, Deer Park, NY 11729: Fax: (516) 586-5562
- (4) Schott Corp., Phone: (612) 475-1173/1000 Parkers Lane Road, Wayzata, MN 55391: Fax: (612) 475-1786

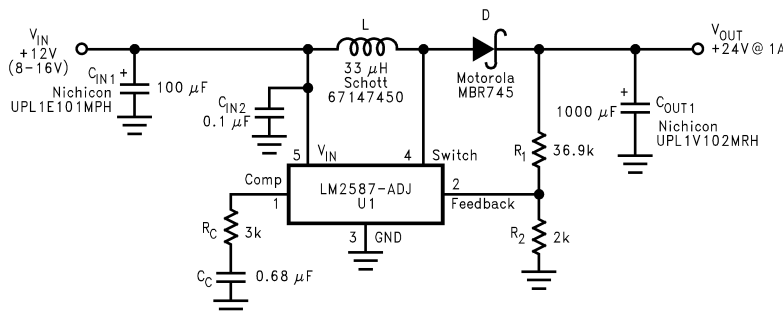

Figure 52. +12V to +24V Boost Regulator

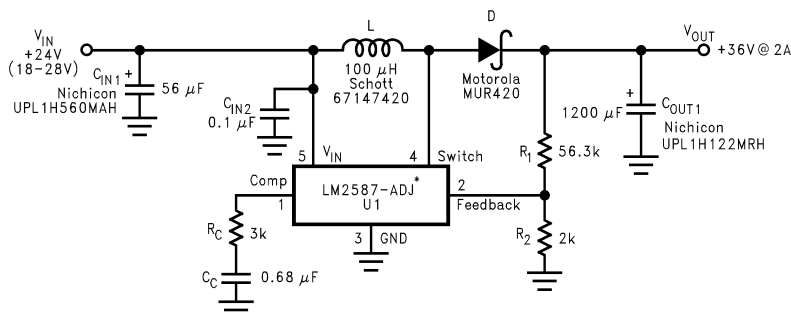
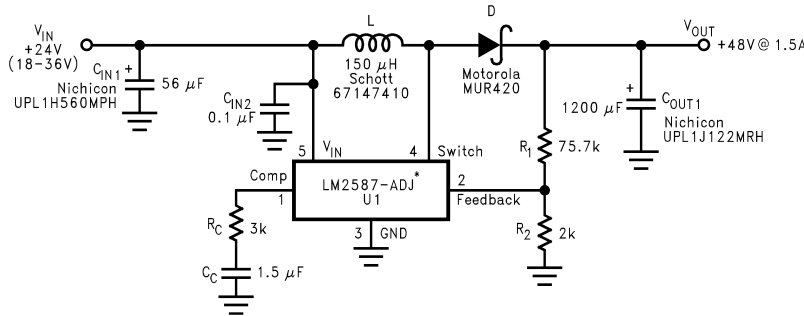

Figure 53. +24V to +36V Boost Regulator



*The LM2587 will require a heat sink in these applications. The size of the heat sink will depend on the maximum ambient temperature. To calculate the thermal resistance of the IC and the size of the heat sink needed, see the "Heat Sink/Thermal Considerations" section in [Application Hints](#).

Figure 54. +24V to +48V Boost Regulator

Application Hints

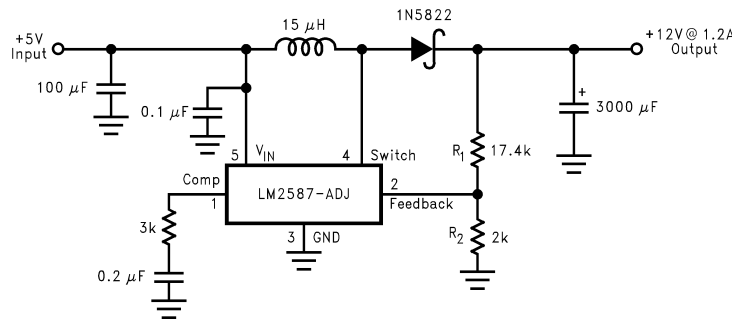

Figure 55. Boost Regulator

PROGRAMMING OUTPUT VOLTAGE (SELECTING R₁ AND R₂)

Referring to the adjustable regulator in [Figure 55](#), the output voltage is programmed by the resistors R₁ and R₂ by the following formula:

$$V_{OUT} = V_{REF} (1 + R_1/R_2) \quad \text{where } V_{REF} = 1.23V \quad (1)$$

Resistors R₁ and R₂ divide the output voltage down so that it can be compared with the 1.23V internal reference. With R₂ between 1k and 5k, R₁ is:

$$R_1 = R_2 (V_{OUT}/V_{REF} - 1) \quad \text{where } V_{REF} = 1.23V \quad (2)$$

For best temperature coefficient and stability with time, use 1% metal film resistors.

SHORT CIRCUIT CONDITION

Due to the inherent nature of boost regulators, when the output is shorted (see [Figure 55](#)), current flows directly from the input, through the inductor and the diode, to the output, bypassing the switch. The current limit of the switch *does not* limit the output current for the entire circuit. To protect the load and prevent damage to the switch, the current must be externally limited, either by the input supply or at the output with an external current limit circuit. The external limit should be set to the maximum switch current of the device, which is 5A.

In a flyback regulator application ([Figure 56](#)), using the standard transformers, the LM2587 will survive a short circuit to the main output. When the output voltage drops to 80% of its nominal value, the frequency will drop to 25 kHz. With a lower frequency, off times are larger. With the longer off times, the transformer can release all of its stored energy before the switch turns back on. Hence, the switch turns on initially with zero current at its collector. In this condition, the switch current limit will limit the peak current, saving the device.

FLYBACK REGULATOR INPUT CAPACITORS

A flyback regulator draws discontinuous pulses of current from the input supply. Therefore, there are two input capacitors needed in a flyback regulator; one for energy storage and one for filtering (see [Figure 56](#)). Both are required due to the inherent operation of a flyback regulator. To keep a stable or constant voltage supply to the LM2587, a storage capacitor ($\geq 100 \mu\text{F}$) is required. If the input source is a rectified DC supply and/or the application has a wide temperature range, the required rms current rating of the capacitor might be very large. This means a larger value of capacitance or a higher voltage rating will be needed of the input capacitor. The storage capacitor will also attenuate noise which may interfere with other circuits connected to the same input supply voltage.

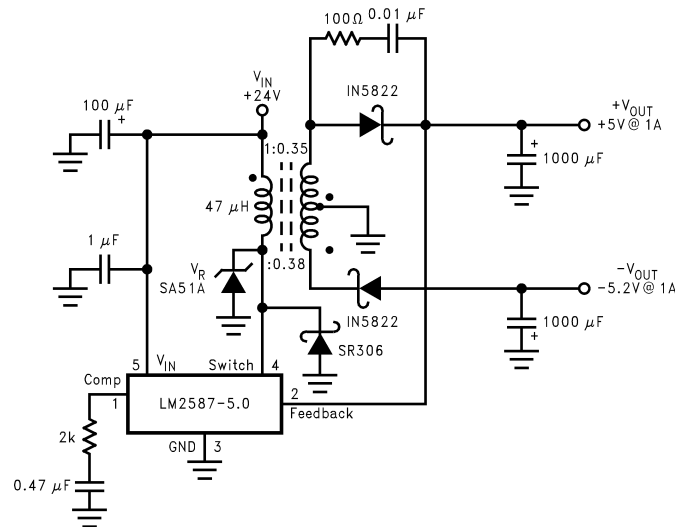

Figure 56. Flyback Regulator

In addition, a small bypass capacitor is required due to the noise generated by the input current pulses. To eliminate the noise, insert a $1.0 \mu\text{F}$ ceramic capacitor between V_{IN} and ground as close as possible to the device.

SWITCH VOLTAGE LIMITS

In a flyback regulator, the maximum steady-state voltage appearing at the switch, when it is off, is set by the transformer turns ratio, N , the output voltage, V_{OUT} , and the maximum input voltage, $V_{\text{IN}} (\text{Max})$:

$$V_{\text{SW(OFF)}} = V_{\text{IN}} (\text{Max}) + (V_{\text{OUT}} + V_{\text{F}})/N \quad (3)$$

where V_{F} is the forward biased voltage of the output diode, and is 0.5V for Schottky diodes and 0.8V for ultra-fast recovery diodes (typically). In certain circuits, there exists a voltage spike, V_{LL} , superimposed on top of the steady-state voltage (see [Figure 22](#), waveform A). Usually, this voltage spike is caused by the transformer leakage inductance and/or the output rectifier recovery time. To “clamp” the voltage at the switch from exceeding its maximum value, a transient suppressor in series with a diode is inserted across the transformer primary (as shown in the circuit on the front page and other flyback regulator circuits throughout the datasheet). The schematic in [Figure 56](#) shows another method of clamping the switch voltage. A single voltage transient suppressor (the SA51A) is inserted at the switch pin. This method clamps the total voltage across the switch, not just the voltage across the primary.

If poor circuit layout techniques are used (see the [CIRCUIT LAYOUT GUIDELINES](#) section), negative voltage transients may appear on the Switch pin (pin 4). Applying a negative voltage (with respect to the IC’s ground) to any monolithic IC pin causes erratic and unpredictable operation of that IC. This holds true for the LM2587 IC as well. When used in a flyback regulator, the voltage at the Switch pin (pin 4) can go negative when the switch turns on. The “ringing” voltage at the switch pin is caused by the output diode capacitance and the transformer leakage inductance forming a resonant circuit at the secondary(ies). The resonant circuit generates the “ringing” voltage, which gets reflected back through the transformer to the switch pin. There are two common methods to avoid this problem. One is to add an RC snubber around the output rectifier(s), as in [Figure 56](#). The values of the resistor and the capacitor must be chosen so that the voltage at the Switch pin does not drop below -0.4V . The resistor may range in value between 10Ω and $1 \text{ k}\Omega$, and the capacitor will vary from $0.001 \mu\text{F}$ to $0.1 \mu\text{F}$. Adding a snubber will (slightly) reduce the efficiency of the overall circuit.

The other method to reduce or eliminate the “ringing” is to insert a Schottky diode clamp between pins 4 and 3 (ground), also shown in [Figure 56](#). This prevents the voltage at pin 4 from dropping below -0.4V . The reverse voltage rating of the diode must be greater than the switch off voltage.

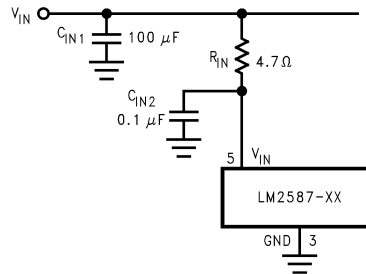

Figure 57. Input Line Filter

OUTPUT VOLTAGE LIMITATIONS

The maximum output voltage of a boost regulator is the maximum switch voltage minus a diode drop. In a flyback regulator, the maximum output voltage is determined by the turns ratio, N , and the duty cycle, D , by the equation:

$$V_{\text{OUT}} \approx N \times V_{\text{IN}} \times D / (1 - D) \quad (4)$$

The duty cycle of a flyback regulator is determined by the following equation:

$$D = \frac{V_{\text{OUT}} + V_{\text{F}}}{N(V_{\text{IN}} - V_{\text{SAT}}) + V_{\text{OUT}} + V_{\text{F}}} \approx \frac{V_{\text{OUT}}}{N(V_{\text{IN}}) + V_{\text{OUT}}} \quad (5)$$

Theoretically, the maximum output voltage can be as large as desired—just keep increasing the turns ratio of the transformer. However, there exists some physical limitations that prevent the turns ratio, and thus the output voltage, from increasing to infinity. The physical limitations are capacitances and inductances in the LM2587 switch, the output diode(s), and the transformer—such as reverse recovery time of the output diode (mentioned above).

NOISY INPUT LINE CONDITION)

A small, low-pass RC filter should be used at the input pin of the LM2587 if the input voltage has an unusual large amount of transient noise, such as with an input switch that bounces. The circuit in [Figure 57](#) demonstrates the layout of the filter, with the capacitor placed from the input pin to ground and the resistor placed between the input supply and the input pin. Note that the values of R_{IN} and C_{IN} shown in the schematic are good enough for most applications, but some readjusting might be required for a particular application. If efficiency is a major concern, replace the resistor with a small inductor (say $10 \mu\text{H}$ and rated at 100mA).

STABILITY

All current-mode controlled regulators can suffer from an instability, known as subharmonic oscillation, if they operate with a duty cycle above 50%. To eliminate subharmonic oscillations, a minimum value of inductance is required to ensure stability for all boost and flyback regulators. The minimum inductance is given by:

$$L(\text{Min}) = \frac{2.92 [(V_{\text{IN}}(\text{Min}) - V_{\text{SAT}}) \times (2D(\text{Max}) - 1)]}{1 - D(\text{Max})} (\mu\text{H}) \quad (6)$$

where V_{SAT} is the switch saturation voltage and can be found in the Characteristic Curves.

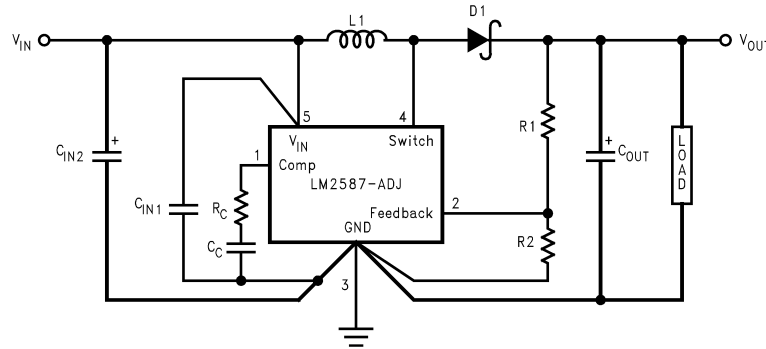

Figure 58. Circuit Board Layout

CIRCUIT LAYOUT GUIDELINES

As in any switching regulator, layout is very important. Rapidly switching currents associated with wiring inductance generate voltage transients which can cause problems. For minimal inductance and ground loops, keep the length of the leads and traces as short as possible. Use single point grounding or ground plane construction for best results. Separate the signal grounds from the power grounds (as indicated in Figure 58). When using the Adjustable version, physically locate the programming resistors as near the regulator IC as possible, to keep the sensitive feedback wiring short.

HEAT SINK/THERMAL CONSIDERATIONS

In many cases, no heat sink is required to keep the LM2587 junction temperature within the allowed operating range. For each application, to determine whether or not a heat sink will be required, the following must be identified:

- 1) Maximum ambient temperature (in the application).
- 2) Maximum regulator power dissipation (in the application).
- 3) Maximum allowed junction temperature (125°C for the LM2587). For a safe, conservative design, a temperature approximately 15°C cooler than the maximum junction temperature should be selected (110°C).
- 4) LM2587 package thermal resistances θ_{JA} and θ_{JC} (given in the Electrical Characteristics).

Total power dissipated (P_D) by the LM2587 can be estimated as follows:

Boost:

$$P_D = 0.15\Omega \times \left(\frac{I_{LOAD}}{1-D} \right)^2 \times D + \frac{I_{LOAD}}{50 \times (1-D)} \times D \times V_{IN}$$

Flyback:

$$P_D = 0.15\Omega \times \left(\frac{N \times \sum I_{LOAD}}{1-D} \right)^2 \times D + \frac{N \times \sum I_{LOAD}}{50 \times (1-D)} \times D \times V_{IN}$$

(7)

V_{IN} is the minimum input voltage, V_{OUT} is the output voltage, N is the transformer turns ratio, D is the duty cycle, and I_{LOAD} is the maximum load current (and $\sum I_{LOAD}$ is the sum of the maximum load currents for multiple-output flyback regulators). The duty cycle is given by:

Boost:

$$D = \frac{V_{OUT} + V_F - V_{IN}}{V_{OUT} + V_F - V_{SAT}} \approx \frac{V_{OUT} - V_{IN}}{V_{OUT}}$$

Flyback:

$$D = \frac{V_{OUT} + V_F}{N(V_{IN} - V_{SAT}) + V_{OUT} + V_F} \approx \frac{V_{OUT}}{N(V_{IN}) + V_{OUT}} \quad (8)$$

where V_F is the forward biased voltage of the diode and is typically 0.5V for Schottky diodes and 0.8V for fast recovery diodes. V_{SAT} is the switch saturation voltage and can be found in the Characteristic Curves.

When no heat sink is used, the junction temperature rise is:

$$\Delta T_J = P_D \times \theta_{JA} \quad (9)$$

Adding the junction temperature rise to the maximum ambient temperature gives the actual operating junction temperature:

$$T_J = \Delta T_J + T_A \quad (10)$$

If the operating junction temperature exceeds the maximum junction temperature in item 3 above, then a heat sink is required. When using a heat sink, the junction temperature rise can be determined by the following:

$$\Delta T_J = P_D \times (\theta_{JC} + \theta_{Interface} + \theta_{Heat\ Sink}) \quad (11)$$

Again, the operating junction temperature will be:

$$T_J = \Delta T_J + T_A \quad (12)$$

As before, if the maximum junction temperature is exceeded, a larger heat sink is required (one that has a lower thermal resistance).

Included in the **Switchers Made Simple** design software is a more precise (non-linear) thermal model that can be used to determine junction temperature with different input-output parameters or different component values. It can also calculate the heat sink thermal resistance required to maintain the regulator junction temperature below the maximum operating temperature.

To further simplify the flyback regulator design procedure, TI is making available computer design software. Switchers Made Simple software is available on a (3½") diskette for IBM compatible computers from a TI sales office in your area or the TI WEBENCH Design Center team.

http://www.ti.com/ww/en/analog/webench/index.shtml?DCMP=hpa_sva_webench&HQS=webench-bb

European Magnetic Vendor Contacts

Please contact the following addresses for details of local distributors or representatives:

Coilcraft

21 Napier Place

Wardpark North Cumbernauld, Scotland G68 0LL Phone: +44 1236 730 595 Fax: +44 1236 730 627

Pulse Engineering

Dunmore Road

Tuam Co. Galway, Ireland Phone: +353 93 24 107 Fax: +353 93 24 459

REVISION HISTORY

Changes from Revision C (April 2013) to Revision D	Page
• Changed layout of National Data Sheet to TI format	24

PACKAGING INFORMATION

Orderable Device	Status (1)	Package Type	Package Drawing	Package Pins	Package Qty	Eco Plan (2)	Lead/Ball Finish (6)	MSL Peak Temp (3)	Op Temp (°C)	Device Marking (4/5)	Samples
LM2587S-12/NOPB	ACTIVE	DDPAK/ TO-263	KTT	5	45	Pb-Free (RoHS Exempt)	CU SN	Level-3-245C-168 HR	-40 to 125	LM2587S -12 P+	Samples
LM2587S-3.3/NOPB	ACTIVE	DDPAK/ TO-263	KTT	5	45	Pb-Free (RoHS Exempt)	CU SN	Level-3-245C-168 HR	-40 to 125	LM2587S -3.3 P+	Samples
LM2587S-5.0	NRND	DDPAK/ TO-263	KTT	5	45	TBD	Call TI	Call TI	-40 to 125	LM2587S -5.0 P+	
LM2587S-5.0/NOPB	ACTIVE	DDPAK/ TO-263	KTT	5	45	Pb-Free (RoHS Exempt)	CU SN	Level-3-245C-168 HR	-40 to 125	LM2587S -5.0 P+	Samples
LM2587S-ADJ	NRND	DDPAK/ TO-263	KTT	5	45	TBD	Call TI	Call TI	-40 to 125	LM2587S -ADJ P+	
LM2587S-ADJ/NOPB	ACTIVE	DDPAK/ TO-263	KTT	5	45	Pb-Free (RoHS Exempt)	CU SN	Level-3-245C-168 HR	-40 to 125	LM2587S -ADJ P+	Samples
LM2587SX-12/NOPB	ACTIVE	DDPAK/ TO-263	KTT	5	500	Pb-Free (RoHS Exempt)	CU SN	Level-3-245C-168 HR	-40 to 125	LM2587S -12 P+	Samples
LM2587SX-5.0/NOPB	ACTIVE	DDPAK/ TO-263	KTT	5	500	Pb-Free (RoHS Exempt)	CU SN	Level-3-245C-168 HR	-40 to 125	LM2587S -5.0 P+	Samples
LM2587SX-ADJ	NRND	DDPAK/ TO-263	KTT	5	500	TBD	Call TI	Call TI	-40 to 125	LM2587S -ADJ P+	
LM2587SX-ADJ/NOPB	ACTIVE	DDPAK/ TO-263	KTT	5	500	Pb-Free (RoHS Exempt)	CU SN	Level-3-245C-168 HR	-40 to 125	LM2587S -ADJ P+	Samples
LM2587T-12	NRND	TO-220	NDH	5		TBD	Call TI	Call TI	-40 to 125	LM2587T -12 P+	
LM2587T-12/NOPB	ACTIVE	TO-220	NDH	5	45	Pb-Free (RoHS Exempt)	CU SN	Level-1-NA-UNLIM	-40 to 125	LM2587T -12 P+	Samples
LM2587T-3.3/NOPB	ACTIVE	TO-220	NDH	5	45	Pb-Free (RoHS Exempt)	CU SN	Level-1-NA-UNLIM	-40 to 125	LM2587T -3.3 P+	Samples
LM2587T-5.0/NOPB	ACTIVE	TO-220	NDH	5	45	Pb-Free (RoHS Exempt)	CU SN	Level-1-NA-UNLIM	-40 to 125	LM2587T -5.0 P+	Samples
LM2587T-ADJ	NRND	TO-220	NDH	5	45	TBD	Call TI	Call TI	-40 to 125	LM2587T -ADJ P+	
LM2587T-ADJ/NOPB	ACTIVE	TO-220	NDH	5	45	Pb-Free (RoHS Exempt)	CU SN	Level-1-NA-UNLIM	-40 to 125	LM2587T -ADJ P+	Samples

(1) The marketing status values are defined as follows:

ACTIVE: Product device recommended for new designs.

LIFEBUY: TI has announced that the device will be discontinued, and a lifetime-buy period is in effect.

NRND: Not recommended for new designs. Device is in production to support existing customers, but TI does not recommend using this part in a new design.

PREVIEW: Device has been announced but is not in production. Samples may or may not be available.

OBSOLETE: TI has discontinued the production of the device.

(2) Eco Plan - The planned eco-friendly classification: Pb-Free (RoHS), Pb-Free (RoHS), Pb-Free (RoHS Exempt), or Green (RoHS & no Sb/Br) - please check <http://www.ti.com/productcontent> for the latest availability information and additional product content details.

TBD: The Pb-Free/Green conversion plan has not been defined.

Pb-Free (RoHS): TI's terms "Lead-Free" or "Pb-Free" mean semiconductor products that are compatible with the current RoHS requirements for all 6 substances, including the requirement that lead not exceed 0.1% by weight in homogeneous materials. Where designed to be soldered at high temperatures, TI Pb-Free products are suitable for use in specified lead-free processes.

Pb-Free (RoHS Exempt): This component has a RoHS exemption for either 1) lead-based flip-chip solder bumps used between the die and package, or 2) lead-based die adhesive used between the die and leadframe. The component is otherwise considered Pb-Free (RoHS compatible) as defined above.

Green (RoHS & no Sb/Br): TI defines "Green" to mean Pb-Free (RoHS compatible), and free of Bromine (Br) and Antimony (Sb) based flame retardants (Br or Sb do not exceed 0.1% by weight in homogeneous material)

(3) MSL, Peak Temp. - The Moisture Sensitivity Level rating according to the JEDEC industry standard classifications, and peak solder temperature.

(4) There may be additional marking, which relates to the logo, the lot trace code information, or the environmental category on the device.

(5) Multiple Device Markings will be inside parentheses. Only one Device Marking contained in parentheses and separated by a "-" will appear on a device. If a line is indented then it is a continuation of the previous line and the two combined represent the entire Device Marking for that device.

(6) Lead/Ball Finish - Orderable Devices may have multiple material finish options. Finish options are separated by a vertical ruled line. Lead/Ball Finish values may wrap to two lines if the finish value exceeds the maximum column width.

Important Information and Disclaimer: The information provided on this page represents TI's knowledge and belief as of the date that it is provided. TI bases its knowledge and belief on information provided by third parties, and makes no representation or warranty as to the accuracy of such information. Efforts are underway to better integrate information from third parties. TI has taken and continues to take reasonable steps to provide representative and accurate information but may not have conducted destructive testing or chemical analysis on incoming materials and chemicals. TI and TI suppliers consider certain information to be proprietary, and thus CAS numbers and other limited information may not be available for release.

In no event shall TI's liability arising out of such information exceed the total purchase price of the TI part(s) at issue in this document sold by TI to Customer on an annual basis.

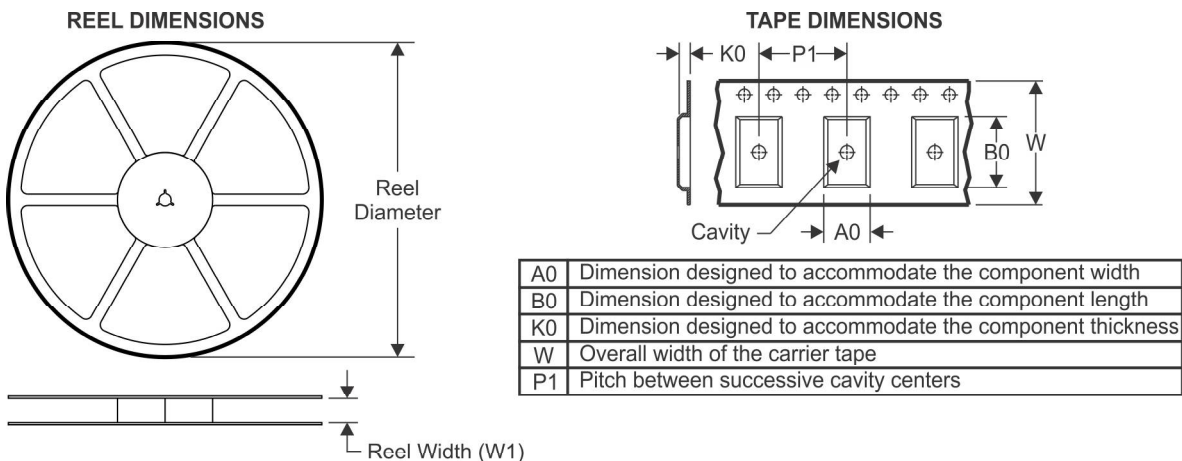
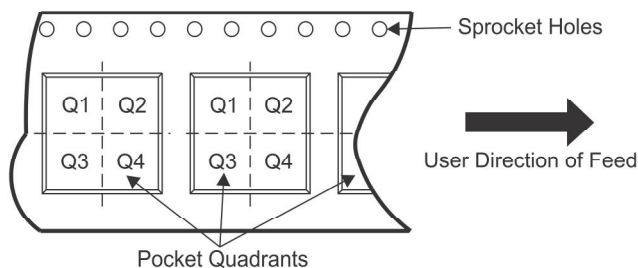
TAPE AND REEL INFORMATION

QUADRANT ASSIGNMENTS FOR PIN 1 ORIENTATION IN TAPE

*All dimensions are nominal

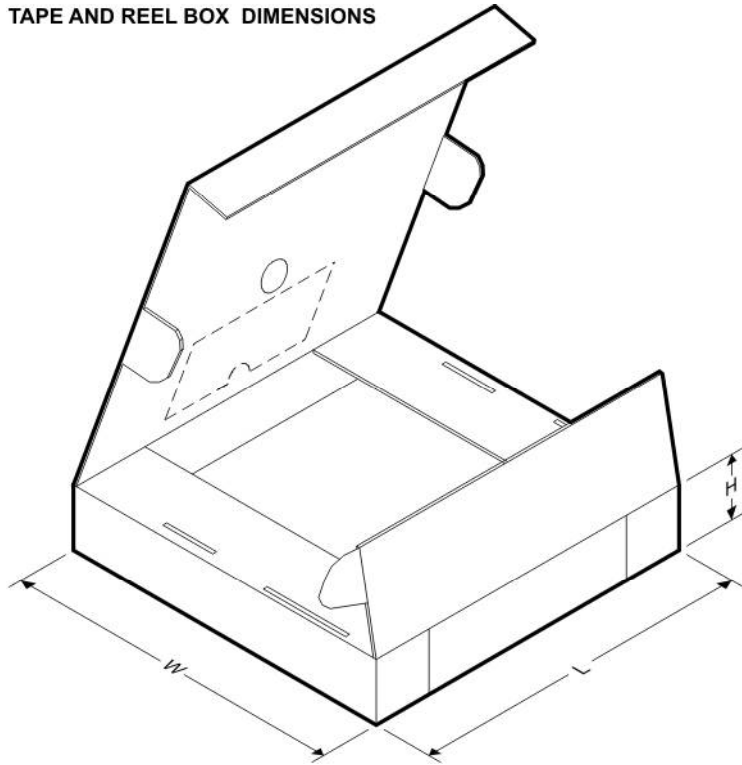
Device	Package Type	Package Drawing	Pins	SPQ	Reel Diameter (mm)	Reel Width W1 (mm)	A0 (mm)	B0 (mm)	K0 (mm)	P1 (mm)	W (mm)	Pin1 Quadrant
LM2587SX-12/NOPB	DDPAK/ TO-263	KTT	5	500	330.0	24.4	10.75	14.85	5.0	16.0	24.0	Q2
LM2587SX-5.0/NOPB	DDPAK/ TO-263	KTT	5	500	330.0	24.4	10.75	14.85	5.0	16.0	24.0	Q2
LM2587SX-ADJ	DDPAK/ TO-263	KTT	5	500	330.0	24.4	10.75	14.85	5.0	16.0	24.0	Q2
LM2587SX-ADJ/NOPB	DDPAK/ TO-263	KTT	5	500	330.0	24.4	10.75	14.85	5.0	16.0	24.0	Q2

TAPE AND REEL BOX DIMENSIONS

*All dimensions are nominal

Device	Package Type	Package Drawing	Pins	SPQ	Length (mm)	Width (mm)	Height (mm)
LM2587SX-12/NOPB	DDPAK/TO-263	KTT	5	500	367.0	367.0	45.0
LM2587SX-5.0/NOPB	DDPAK/TO-263	KTT	5	500	367.0	367.0	45.0
LM2587SX-ADJ	DDPAK/TO-263	KTT	5	500	367.0	367.0	45.0
LM2587SX-ADJ/NOPB	DDPAK/TO-263	KTT	5	500	367.0	367.0	45.0

NDH0005D

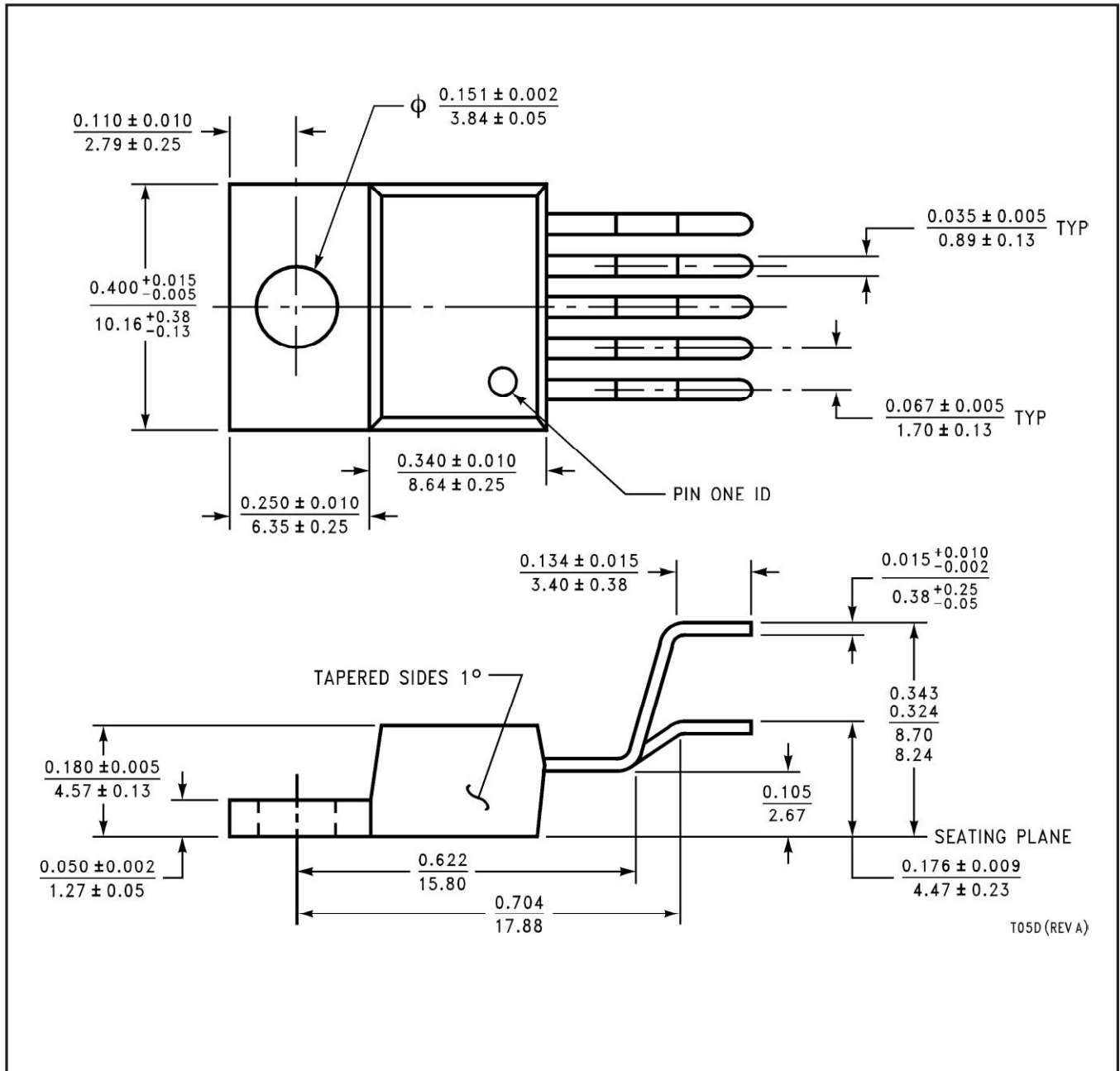

KTT0005B

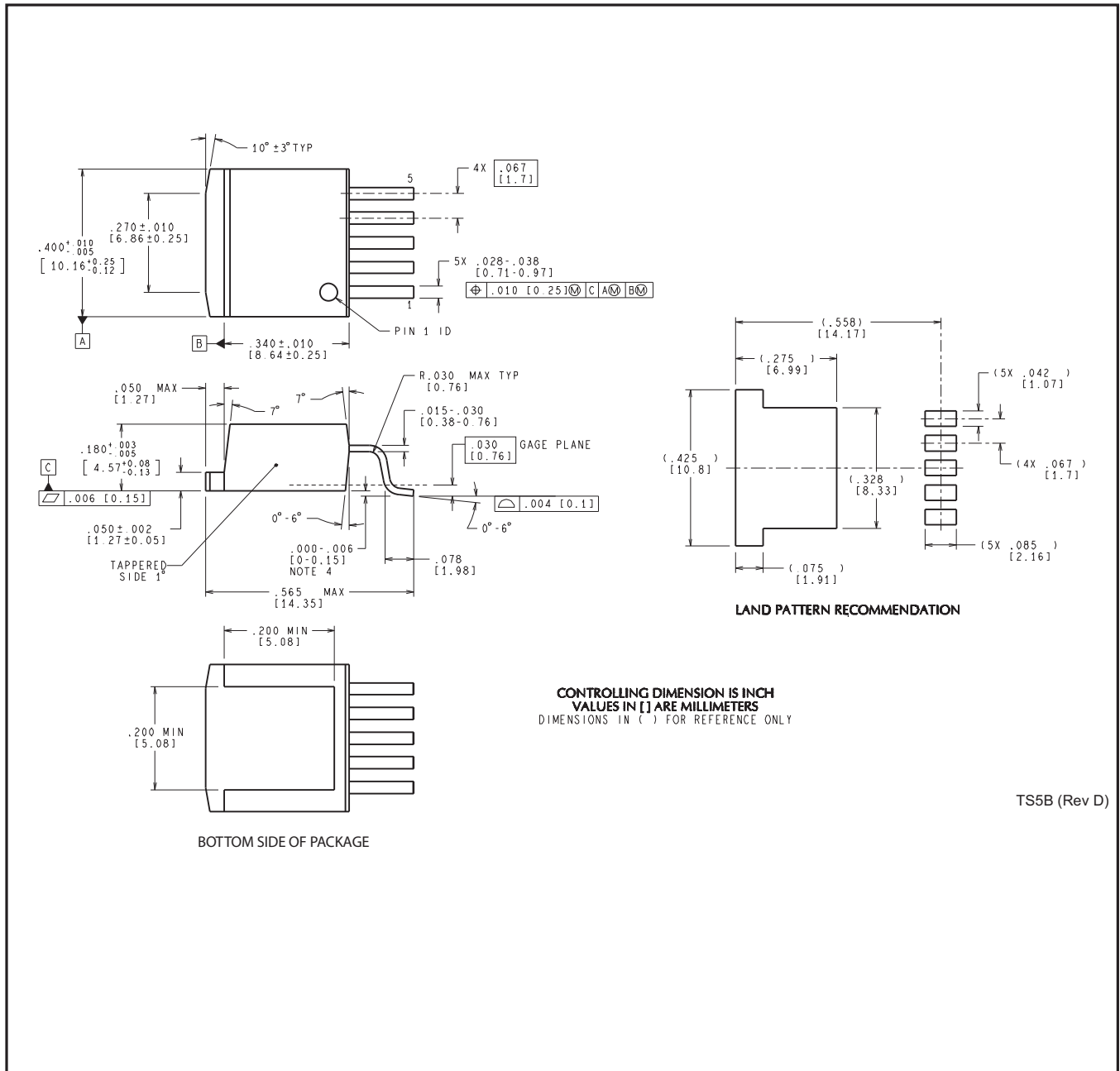

TS5B (Rev D)

IMPORTANT NOTICE

Texas Instruments Incorporated and its subsidiaries (TI) reserve the right to make corrections, enhancements, improvements and other changes to its semiconductor products and services per JESD46, latest issue, and to discontinue any product or service per JESD48, latest issue. Buyers should obtain the latest relevant information before placing orders and should verify that such information is current and complete. All semiconductor products (also referred to herein as "components") are sold subject to TI's terms and conditions of sale supplied at the time of order acknowledgment.

TI warrants performance of its components to the specifications applicable at the time of sale, in accordance with the warranty in TI's terms and conditions of sale of semiconductor products. Testing and other quality control techniques are used to the extent TI deems necessary to support this warranty. Except where mandated by applicable law, testing of all parameters of each component is not necessarily performed.

TI assumes no liability for applications assistance or the design of Buyers' products. Buyers are responsible for their products and applications using TI components. To minimize the risks associated with Buyers' products and applications, Buyers should provide adequate design and operating safeguards.

TI does not warrant or represent that any license, either express or implied, is granted under any patent right, copyright, mask work right, or other intellectual property right relating to any combination, machine, or process in which TI components or services are used. Information published by TI regarding third-party products or services does not constitute a license to use such products or services or a warranty or endorsement thereof. Use of such information may require a license from a third party under the patents or other intellectual property of the third party, or a license from TI under the patents or other intellectual property of TI.

Reproduction of significant portions of TI information in TI data books or data sheets is permissible only if reproduction is without alteration and is accompanied by all associated warranties, conditions, limitations, and notices. TI is not responsible or liable for such altered documentation. Information of third parties may be subject to additional restrictions.

Resale of TI components or services with statements different from or beyond the parameters stated by TI for that component or service voids all express and any implied warranties for the associated TI component or service and is an unfair and deceptive business practice. TI is not responsible or liable for any such statements.

Buyer acknowledges and agrees that it is solely responsible for compliance with all legal, regulatory and safety-related requirements concerning its products, and any use of TI components in its applications, notwithstanding any applications-related information or support that may be provided by TI. Buyer represents and agrees that it has all the necessary expertise to create and implement safeguards which anticipate dangerous consequences of failures, monitor failures and their consequences, lessen the likelihood of failures that might cause harm and take appropriate remedial actions. Buyer will fully indemnify TI and its representatives against any damages arising out of the use of any TI components in safety-critical applications.

In some cases, TI components may be promoted specifically to facilitate safety-related applications. With such components, TI's goal is to help enable customers to design and create their own end-product solutions that meet applicable functional safety standards and requirements. Nonetheless, such components are subject to these terms.

No TI components are authorized for use in FDA Class III (or similar life-critical medical equipment) unless authorized officers of the parties have executed a special agreement specifically governing such use.

Only those TI components which TI has specifically designated as military grade or "enhanced plastic" are designed and intended for use in military/aerospace applications or environments. Buyer acknowledges and agrees that any military or aerospace use of TI components which have *not* been so designated is solely at the Buyer's risk, and that Buyer is solely responsible for compliance with all legal and regulatory requirements in connection with such use.

TI has specifically designated certain components as meeting ISO/TS16949 requirements, mainly for automotive use. In any case of use of non-designated products, TI will not be responsible for any failure to meet ISO/TS16949.

Products

Audio	www.ti.com/audio
Amplifiers	amplifier.ti.com
Data Converters	dataconverter.ti.com
DLP® Products	www.dlp.com
DSP	dsp.ti.com
Clocks and Timers	www.ti.com/clocks
Interface	interface.ti.com
Logic	logic.ti.com
Power Mgmt	power.ti.com
Microcontrollers	microcontroller.ti.com
RFID	www.ti-rfid.com
OMAP Applications Processors	www.ti.com/omap
Wireless Connectivity	www.ti.com/wirelessconnectivity

Applications

Automotive and Transportation	www.ti.com/automotive
Communications and Telecom	www.ti.com/communications
Computers and Peripherals	www.ti.com/computers
Consumer Electronics	www.ti.com/consumer-apps
Energy and Lighting	www.ti.com/energy
Industrial	www.ti.com/industrial
Medical	www.ti.com/medical
Security	www.ti.com/security
Space, Avionics and Defense	www.ti.com/space-avionics-defense
Video and Imaging	www.ti.com/video

TI E2E Community

e2e.ti.com