

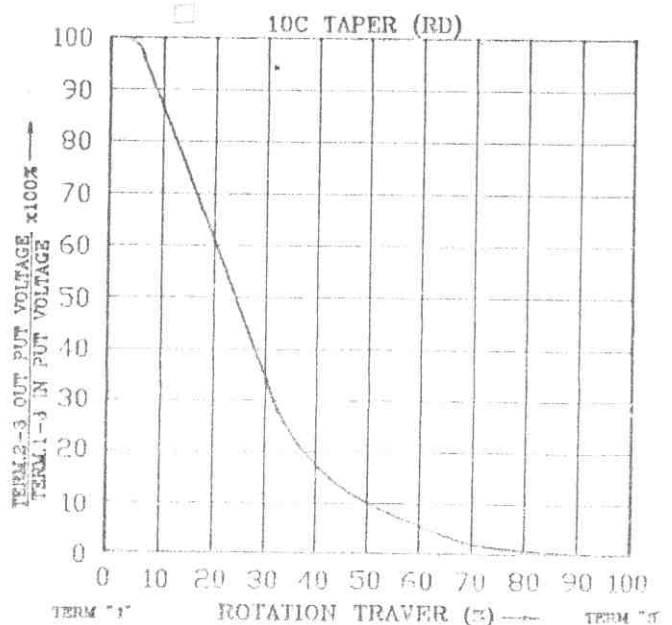

# STANDARD RESISTANCE TAPER

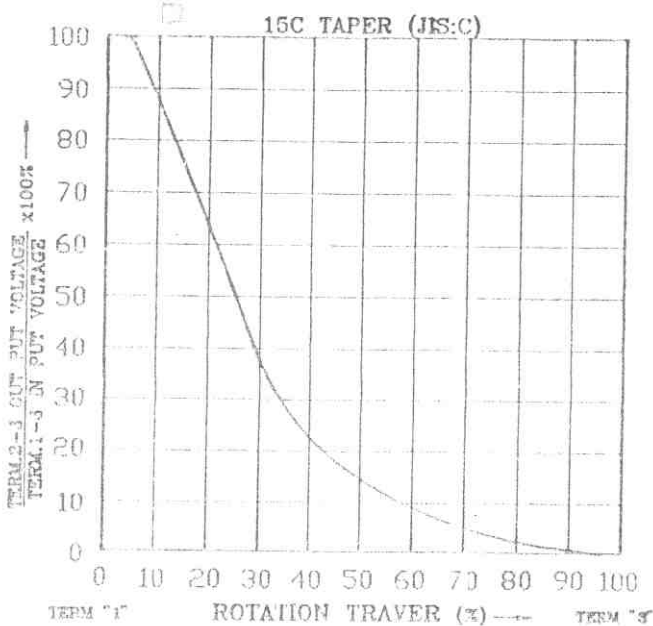

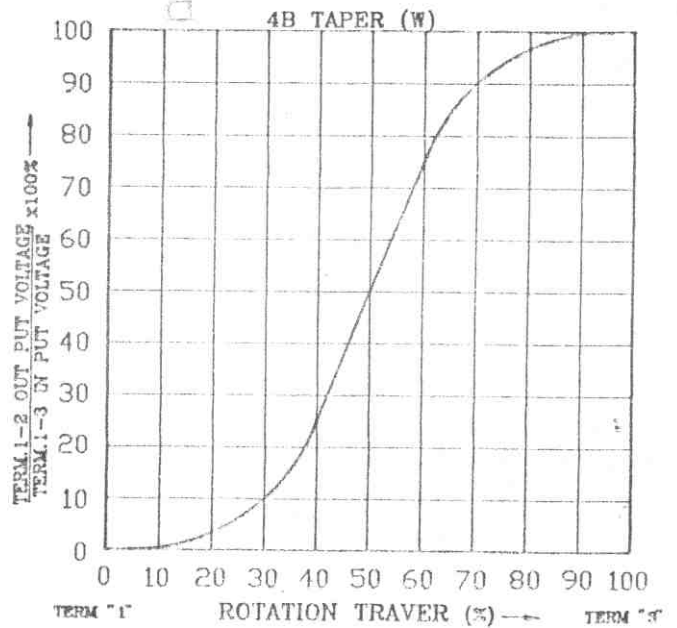
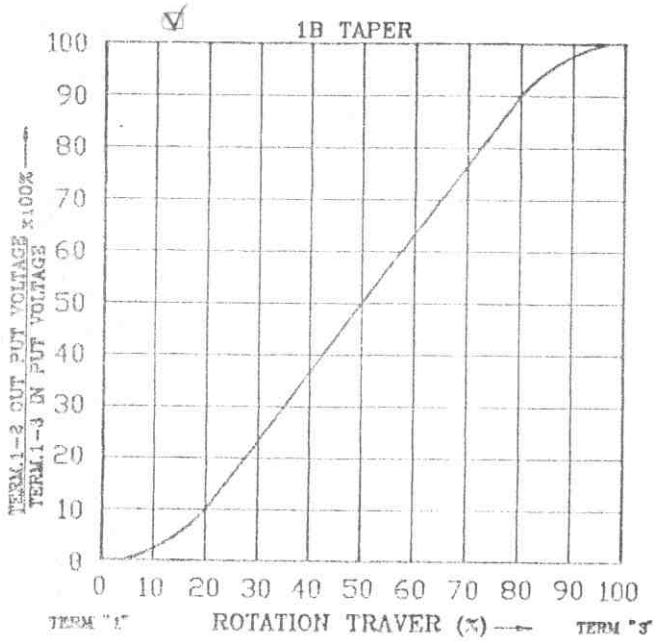
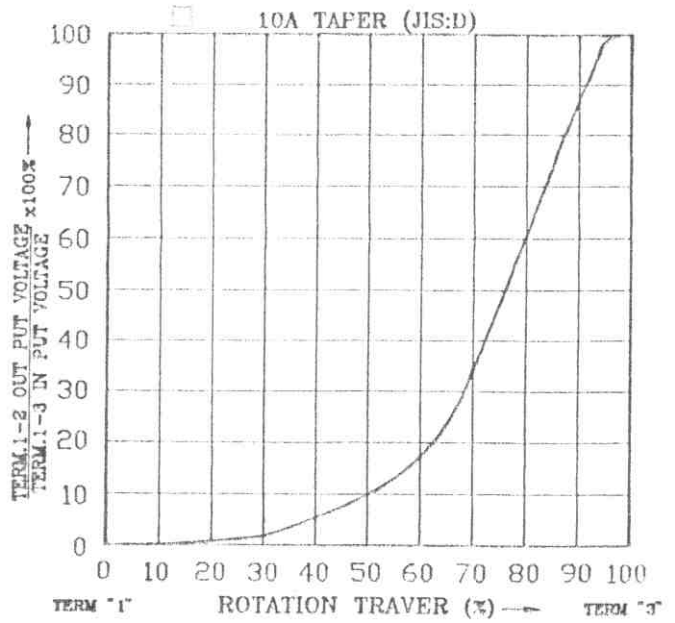
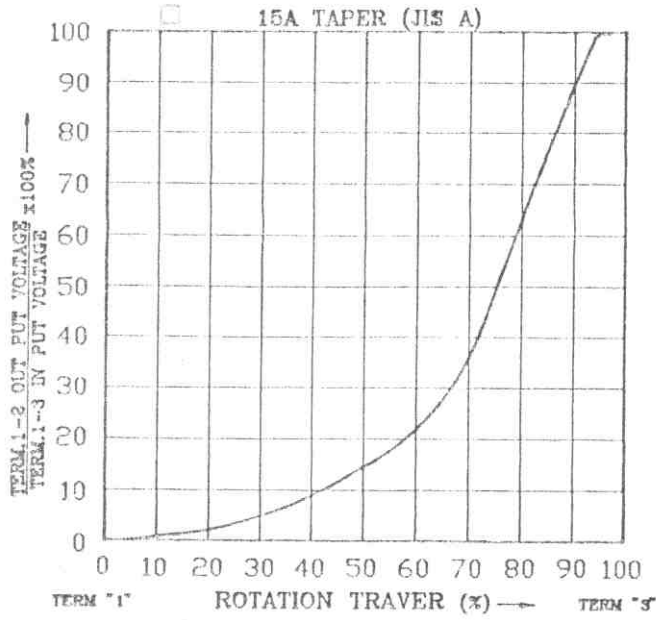
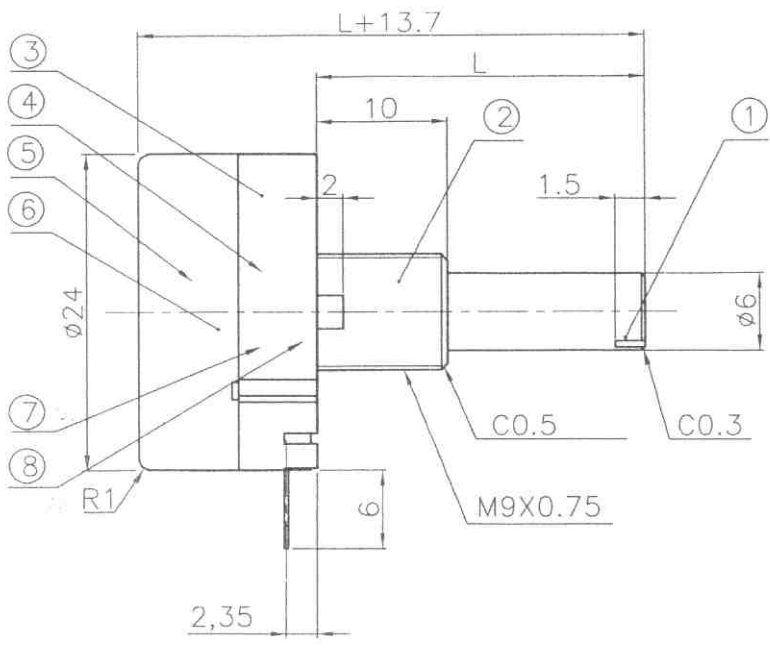

SHAFT SHOWN IN FULL C.C.W. POSITION

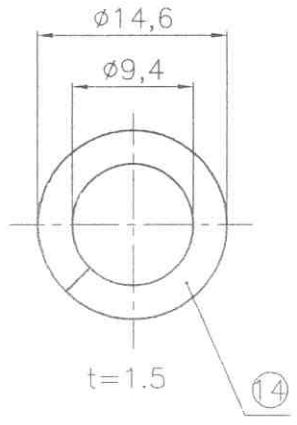
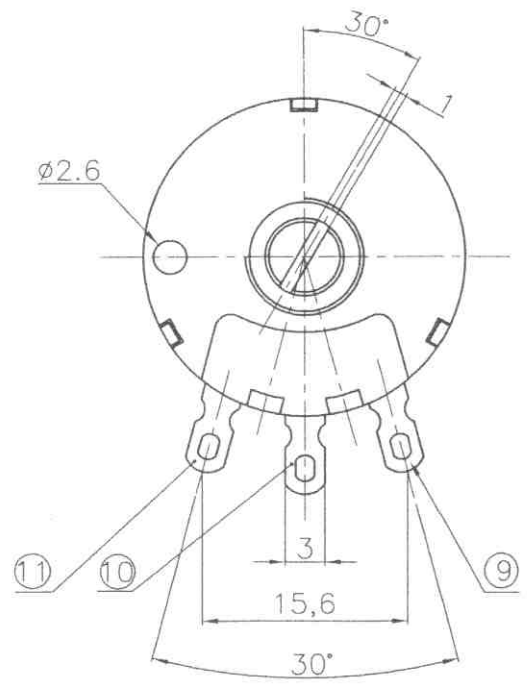

Spring Washer 1PC

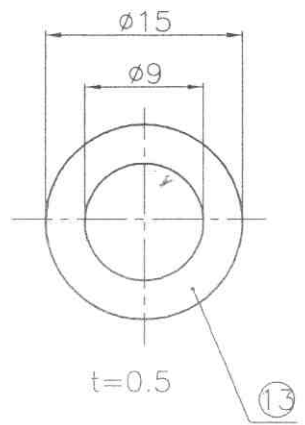

Spring 1PC

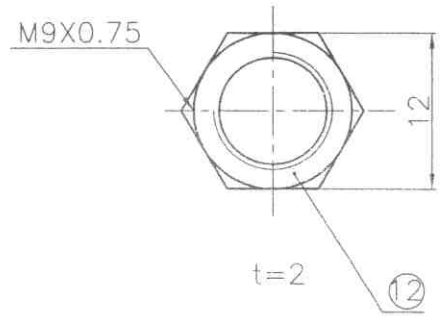

Nut 1PC

15	TG-54	Grease	A/R	
14	W-9	Spring Washer	1	Steel
	W-9	Washer	1	Steel
12	N-9	Nut	1	Steel
11	R24C05R	Terminal Lug	1	Copper Tape
10	R24C05M	Terminal Lug	1	Phosphor-Bronze
9	R24C05L	Terminal Lug	1	Copper Tape
8	R24C23	Bracket plate	1	Spcc
7	R24C08	Block	1	POM
6	R24C09	Case	1	Brass
5	R24C07	Wiper	1	Phosphor-Bronze
4	R24C04	Resistor Element	1	Fiberglass
3	R24C11	Basic	1	POM
2	R24C02	Bushing	1	Brass
1	R24C01-S	Shaft	1	Brass

NO	MODEL	L
✓	20S	20
	25S	25
	30S	30
	40S	40
	50S	50

NO	MODEL	L

NO	Part No	Description	Q'TY	Material	Finishing	MODEL NAME	R24C-10-20S-B100K[G]A
TOLERANCES		DIMENSION	SCALE	DRAWIN BY	CHECKED BY	APPROVED BY	DRAWING NO.
less than	10	± 0.3	m/m	/	楊	江	R24C-001
above	10 - 30	± 0.5					
above	30 - 100	± 1.0					
angular dimension		± 5°					

# 樣品檢查報告表

客戶 CUSTOMER:

贊順企業有限公司

DATE: 2010.11.10

品名 MODEL NO.	R24C-10-20S-B100K(G)	APPROVAL	INSPECTOR
數量 QUANTITY	3 PCS		崔彥魁
檢查 INSPECTION	<input type="checkbox"/> 機械 MECHANICAL <input type="checkbox"/> 電氣 ELECTRICAL		

## 機械及電氣規格檢驗項目      MECHANICAL & ELECTRICAL INSPECTION ITEM

NO	迴轉角度	迴轉轉矩	止動強度	全阻值	殘留阻值		轉動雜音	絕緣阻抗	耐電壓	尺寸檢查
	OVERALL	OPERATION	STOP	OVERALL	RESIDUAL		ROTATION	INSULA	DIELEC	DIMENSION
	ROTATION	TORQUE	STRENGTH	RESISTANCE	RESISTANCE		NOISE	-TION	-TRIC	INSPECT
	°	gf.cm	Kgf.cm	K OHM	1-2/ <math>2</math>ohm	2-3/ <math>3</math>ohm	mV	>100M ohm	1 MINUTE	20mm±0.5mm
1	298	62	OK	105.0	0.5	0.6	3.8	OK	OK	20.13
2	299	58	OK	106.6	0.6	0.6	2.9	OK	OK	19.90
3	300	56	OK	104.4	0.6	0.6	5.5	OK	OK	20.03
4										
5										
6										
7										
8										
9										
10										
11										
12										
13										
14										
15										
16										
17										
18										
19										
20										
21										
22										
23										
24										
25										
26										
27										
28										
29										
30										



ISO-9001:2000 110610015  
ISO-14001:2004 120811013

# 承認書

## SPECIFICATION

編號(NO): C10A019

日期(DATE): 2010.11.10

客戶名稱 (CUSTOMER'S NAME): 贊順企業有限公司

華炬品名 (OUR PART NAME): R24C-10-20S-B100K(G)

客戶品名(CUSTOMER'S PART NAME): \_\_\_\_\_

客 戶 承 認

核 准	審 核	經 辦 者
李躍鑫	崔彥魁	吳從榮

**博羅縣石灣鎮華炬電子有限公司**  
**HUA JU ELECTRONICS LTD.**

TEL:86-752-6905901~902      FAX:86-752-6901299

中國廣東省惠州市博羅縣石灣鎮里波水管理區  
LiBo shui, Shi Wan Town, Poluo County,  
Huizhou City, Guang Dong Province, China

http://www.igee-bio.com      E-mail: bio@igee-bio.com