

00-00-8710-SL-HS

版本 A/01

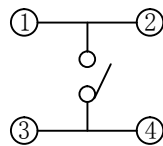

电路图

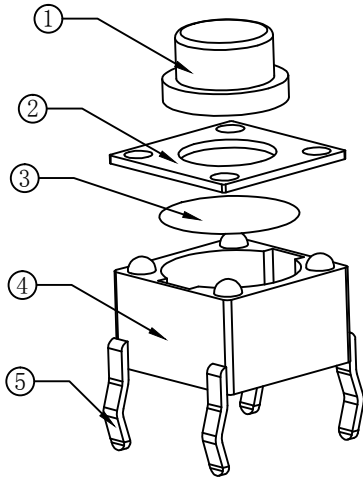
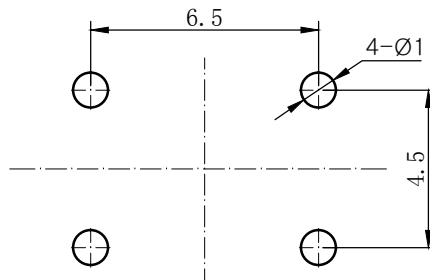
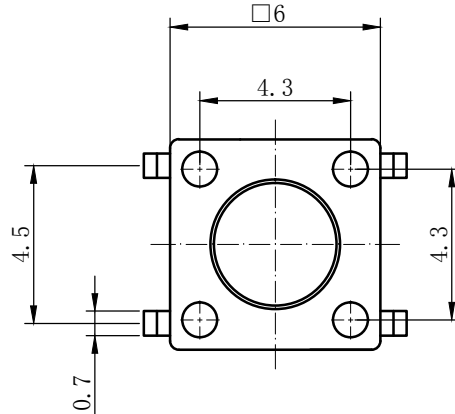

PCB线路板安装图(±0.1)

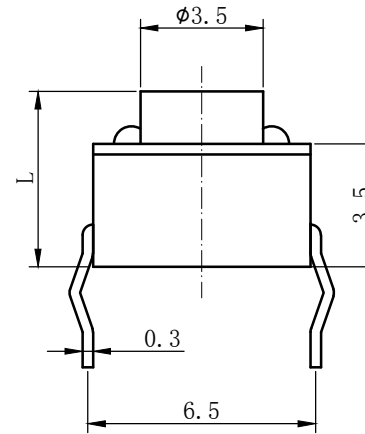

SPECIFICATIONS:

1. Rating: DC12V, 50mA;
2. Contact Resistance: 100mΩ Max;
3. Operating Force: 160±30gf
4. Travel: 0.25±0.1mm
5. Insulation Resistance: 100MΩ Max;
6. Withstand Voltage: 250V 1Min
7. Operating Life: 100,000cycler Min

29	SH-TS-0128-00-29	26.0
28	SH-TS-0128-00-28	24.0
27	SH-TS-0128-00-27	22.0
26	SH-TS-0128-00-26	21.0
25	SH-TS-0128-00-25	20.0
24	SH-TS-0128-00-24	19.0
23	SH-TS-0128-00-23	18.0
22	SH-TS-0128-00-22	17.0
21	SH-TS-0128-00-21	16.0
20	SH-TS-0128-00-20	15.0
19	SH-TS-0128-00-19	14.0
18	SH-TS-0128-00-18	13.0
17	SH-TS-0128-00-17	12.5
16	SH-TS-0128-00-16	12.0
15	SH-TS-0128-00-15	11.0
14	SH-TS-0128-00-14	10.5
13	SH-TS-0128-00-13	10.0
12	SH-TS-0128-00-12	9.5
11	SH-TS-0128-00-11	9.0
10	SH-TS-0128-00-10	8.5
9	SH-TS-0128-00-09	8.0
8	SH-TS-0128-00-08	7.5
7	SH-TS-0128-00-07	7.0
6	SH-TS-0128-00-06	6.5
5	SH-TS-0128-00-05	6.0
4	SH-TS-0128-00-04	5.5
3	SH-TS-0128-00-03	5.0
2	SH-TS-0128-00-02	4.5
1	SH-TS-0128-00-01	4.3
序号	图样编号	高度L(mm)

未注公差(±)

等级	A级	B级	C级
0~4	0.05	0.10	0.20
4~16	0.08	0.15	0.30
16~64	0.12	0.25	0.50
CAD绘图	0.25	0.40	0.80

序号	名称	图样编号	数量	材料	附注	批准
5	嵌件	SH-TS-0128-05-00	1	H62Y T=0.3	Cu/Ep: CuSn2	
4	底座	SH-TS-0128-04-00	1	PA66 黑色		设计 徐德安 2012.5.17
3	簧片	SH-TS-0128-03-00	1	复银钢带 T=0.1		审核
2	盖板	SH-TS-0128-02-00	1	冷轧钢带 T=0.3	Cu/Ep: CuSn2	工艺
1	帽头	SH-TS-0128-01-00	1	PA66 黑色		标准化
序号	名称	图样编号	数量	材料	附注	批准

SH-128  
外形图

SH-TS-0128-00-00

阶段标记	重量(g)	比例
		5:1
第 1 页	共 1 页	