

# SHUANGLIN

## Specifications

Product Name: AC Generator

Product model: SL-300FZ

## Product Dimensions:

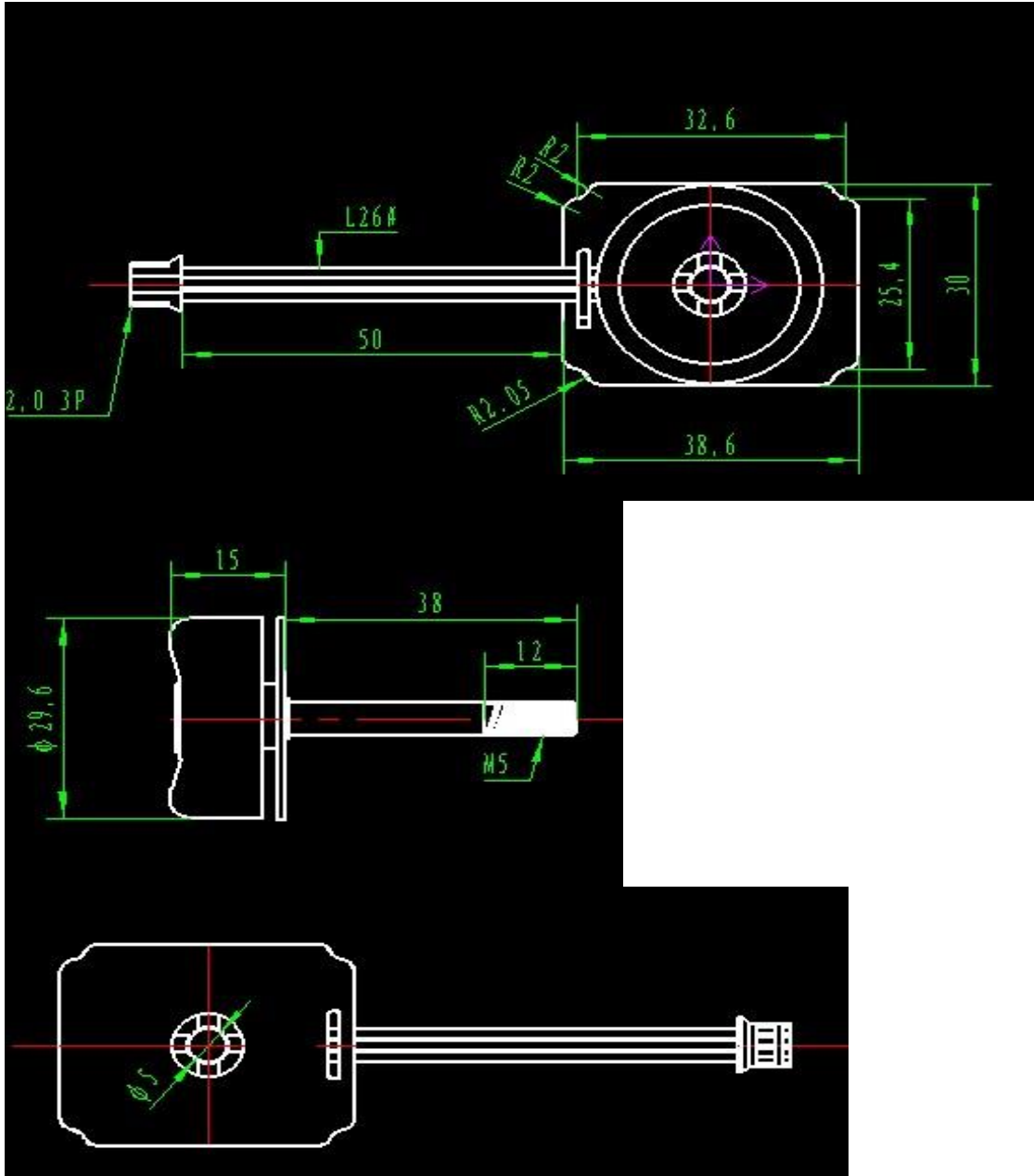

Product Type: Brushless Three-phase external rotor alternator

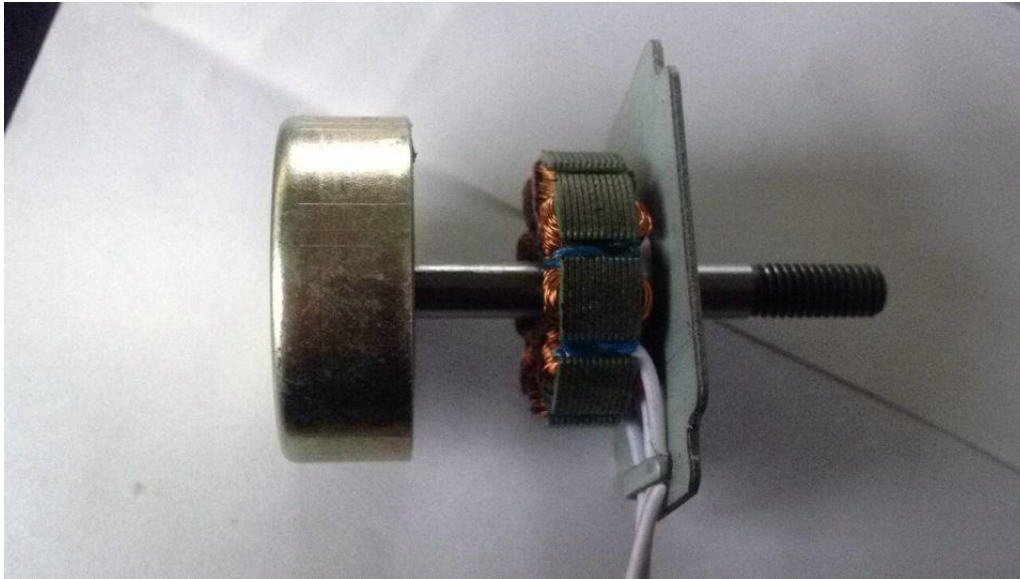

### Product Electrical Parameters

Motor Speed: 3000RPM

Rated Output Voltage: AC Three-phase 10V

Rated Output Power: 4.5W

### Motor Rectification Method:

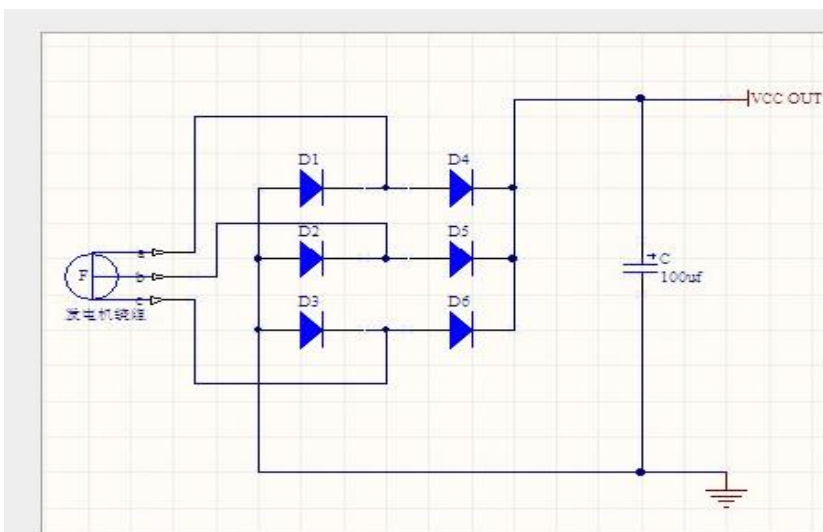

Motor Protection Grade: IP01

Life Span: 20000H

Working Environment: -20 - +70 degrees

Humidity < 90%

Impact Test: Axial Impact Force 20N

Radial Impact Force: 0.2N

Storage of the Environment -40 - +80 degrees

Starting Torque: 120G: CM