

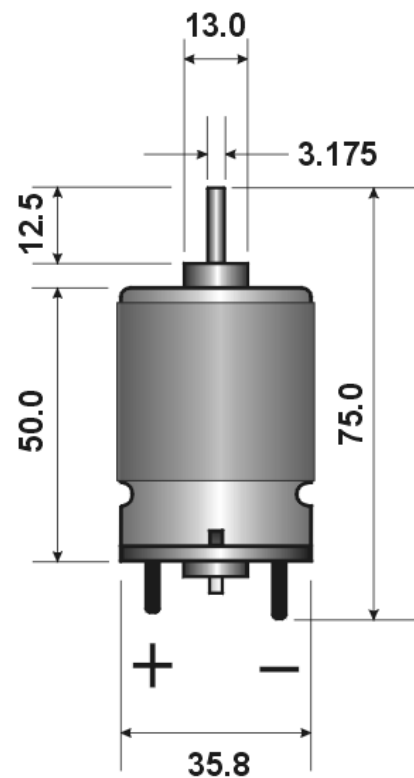

SR555S - 18150P – 75R – 03

CHARACTERISTICS		
Voltage	12 to 24V DC	
No load @ 24V	Current	0.1A
	Speed	3,900 rpm
At Max. efficiency @ 24V	Current	0.44A
	Torque	200g.cm
	Speed	3,300 rpm
Maximum load @ 24V	Current	1.2A
	Torque	660g.cm
	Speed	1,900 rpm
Shaft diameter	3.175mm	



APPLICATIONS

NOTES
