



# SRK383S

適用於 **Typical Application:**

發剪 Hair Clipper

水泵 Water Pump

曲奇餅機 Cookie Maker

標準軸 **Standard Shaft:** 51, 57 (mm)

電刷 **Brush Type:** 碳精 Carbon

端蓋 **End Bell:** 膠蓋 Plastic

型號 Model	工作範圍 Operating Range	工作電壓 Nominal Voltage	空載 At No Load		最大效率 At Max. Efficiency					最大功率 At Max. Output					堵轉 At Stall	
			轉速 Speed	電流 Current	轉速 Speed	電流 Current	扭力 Torque	功率 Output	效率 Efficiency	轉速 Speed	電流 Current	扭力 Torque	功率 Output	效率 Efficiency	電流 Current	扭力 Torque
			RPM	A	RPM	A	g.cm	W	%	RPM	A	g.cm	W	%	A	g.cm
SRHK383S-4040P	3.0-7.5	6.0	17300	0.661	14600	3.565	101.6	15.217	71.1	8650	9.615	325.0	28.832	48.3	19.230	649.9
SRK383S-3270P	6.0-15.0	12.0	18700	0.342	15880	1.931	101.8	16.577	71.6	9350	5.450	338.2	32.419	48.1	10.900	676.3
SRK383S-12380P	24.0-36.0	24.0	7030	0.055	5740	0.247	63.9	3.762	63.6	3510	0.553	175.1	6.306	44.8	1.105	350.1
SRHK383S-19180P	6.0-18.0	6.0	3490	0.112	2730	0.401	49.9	1.399	58.1	1750	0.718	114.4	2.049	43.2	1.436	228.8
SRHK383S-3085P	9.0-18.0	12.0	15360	0.358	13030	2.002	126.3	16.880	70.3	7680	5.600	416.4	32.797	46.8	11.200	832.8

Direction Of Rotation

轉向

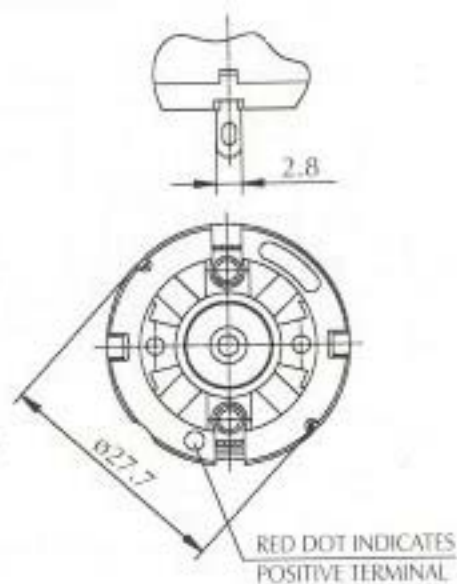
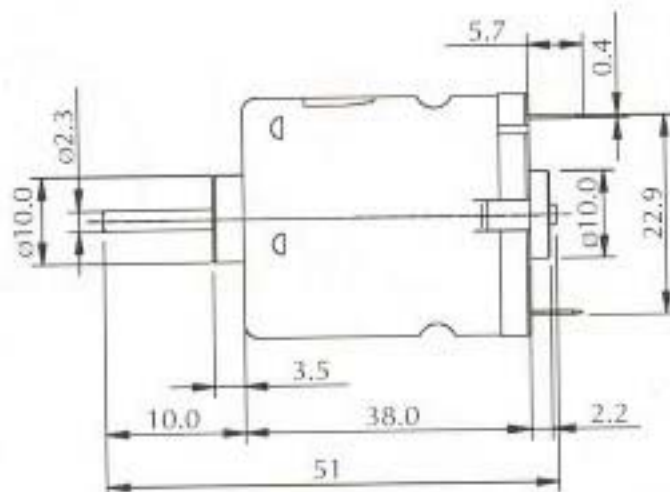
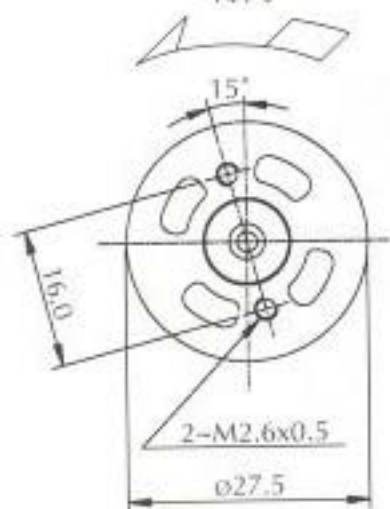

RED DOT INDICATES  
POSITIVE TERMINAL

The terminal position against the tapped holes varies of 15°, 0° & -15°  
牙孔相對端子的位置有15°, 0° & -15°

Usable male screw length engaged into the tapped hole is 2.8mm Max.  
M2.6的螺絲深入螺孔最大深度為2.8mm

The Shaft length can be regulated according to the customer's require.